

CE

Approved for Digital
Weigh Indicator

Digital Weighing Indicator SI 580E

Instruction Manual



Ver. 1.31 July 2011

CONTENTS

1. Before Installation	-----	3 Page
2. Introduction	-----	4 Page
3. Specification	-----	5 Page
4. Installation	-----	9 Page
4-1. External Dimension & Cutting Size	-----	9 Page
4-2. Installation Components	-----	9 Page
4-3. Load Cell Installation	-----	10 Page
5. Set up	-----	11 Page
5-1. Set Up	-----	11 Page
5-2. TEST Weight Calibration Mode	-----	13 Page
5-3. Simulating Calibration Mode	-----	17 Page
5-4. F-FUNCTION Setting	-----	21 Page
5-5 SET-POINT Setting	-----	30 Page
5-6. Test Mode	-----	39 Page
6. Interface	-----	43 Page
6-1. Serial Interface	-----	43 Page
6-2. Relay Output	-----	55 Page
6-3. Analog Output Interface(4~20mA)	-----	56 Page
6-4. Analog Output Interface(0~10V)	-----	57 Page
6-5. Serial Print	-----	58 Page
7. Error & Treatment	-----	61 Page
Warrantee Certificate	-----	62 Page

1. BEFORE INSTALLATION

Caution / Warning Marks



This mark warns the possibility to arrive death or serious injury in case of wrongly used.



This mark cautions the possibility to arrive serious human body injury or product lose in case of wrongly used.

Copy Rights

1. All Right and Authority for this Manual is belonged to SEWHA CNM CO., LTD.
2. Any kinds of copy or distribution without permission of SEWHA CNM CO., LTD. will be prohibited.
3. This manual may be changed as the version is upgraded, without previous notice.

Inquiries

If you have any kinds of inquiries for this model, please contact your local agent or Head Office.

Head Office : SEWHA CNM CO., LTD.

Website : <http://www.sewhacnm.co.kr>

Email : sales@sewhacnm.co.kr

2. INTRODUCTION

2-1. Introduction

Thank you for your choice of this SI580E Industrial Digital Weighing Controller.

This SI580E model is high-performance weighing controller.

SI 580E model has various kinds of "Weighing Modes" – with 4pcs Control Relay output.

And it has 2ports serial interface, and Analogue Output(0~10V or 4~20mA - Selectable).

Please review and learn this instruction Manual and enjoy your process efficiency with

"SI 580E" Digital Weighing Controller.



2-2. Cautions

1. Don't drop on the ground and avoid serious external damage on item.
2. Don't install under sunshine or heavy vibrated condition.
3. Don't install place where high voltage or heavy electric noise condition.
4. When you connect with other devices, please turn off the power of item.
5. Avoid from water damage.
6. For the improvement of function or performance, we can change item specification without previous notice or permission.
7. Item's performance will be up-dated continuously base on previous version's performance.

2-3. Features

1. SI 580E model is the standard 1/8 DIN SIZE and compact enough, so it is easy to install.
2. Front panel is covered with Polycarbonate film, strong against dust and water.
3. There are standard installed with RS-422&RS-232C or RS-485&RS-232C.
4. The user can select the analog output , 4~20mA(default) / 0~10V.

SI 580E DIN SIZE WEIGHING CONTROLER

3. SPECIFICATION

3-1 Specification

Content		Specification	
Performance	External Resolution	1/20,000	
	Internal Resolution	1/2,097,152 (±1,048,576)	
	Input Sensitivity	Min. 0.1μV/V	
	Max. Signal Input Voltage	Max.3.2mV/V	
	Load cell Excitation	DC +5V	
	A/D Conversion Method	Sigma-Delta	
	Decimal Point	0, 0.0, 0.00, 0.000	
	Drift	Offset	10PPM/°C
		Span	10PPM/°C
	Linearity	0.001% of Full Scale	
Analogue Sampling(sec)	60times / sec		
Environment	Operating Temperature Range	-10°C ~ +40°C [14°F ~ 104°F]	
	Operation Humidity Range	40% ~ 85% RH, Non-condensing	
Function	Calibration Mode	Test Weight Calibration Mode Simulation Calibration Mode (Without Test Weight)	
	Display	6 digit, 15mm(0.6inch) Red Color FND	
	Key Pad	5EA Standard Key	
	Digital Input	4pcs Digital Input	
Communication	Serial Port1 (RS-422/485)	Data Transference Command Mode Serial Print	
	Serial Port2 (RS-232)		
Control Output	Analogue Output	0~10V / 4~20mA User selection	
	Control Relay Output Card	4pcs Control Relay	
Power	Input Power DC 24V Power Consumption Max. 8W		
Size	96mm(W) x 48mm(H) x 135mm(D) Including Connector Weight : 350g		

SI 580E DIN SIZE WEIGHING CONTROLLER

3-2. Front Panel

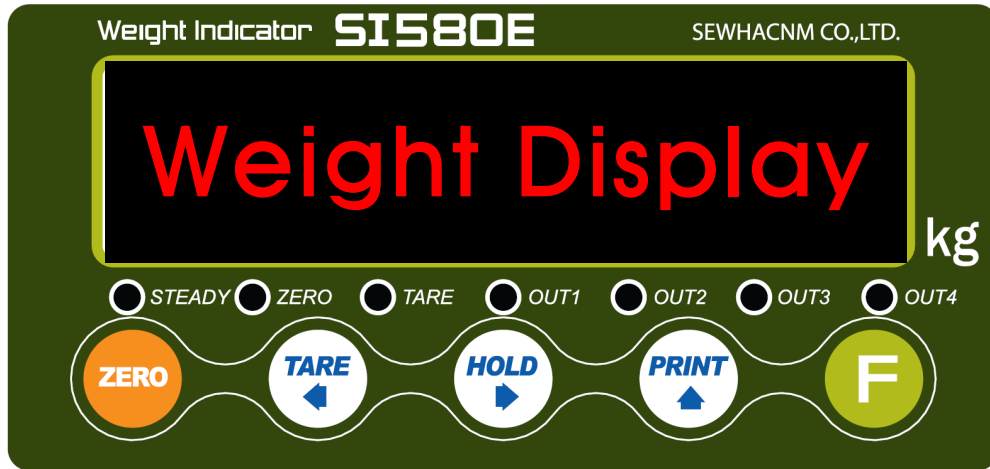

3-2-1 Front Panel (Display / Key Pad)





3-2-1. Status Lamp

STEADY	When the weight is "STEADY", Lamp is ON.
ZERO	When the current weight is "ZERO", Lamp is ON.
TARE	"TARE" function is set, Lamp is ON.
HOLD	"HOLD" function is set, Lamp is ON.
OUT1	When "OUT1"(Relay) operates, Lamp is ON
OUT2	When "OUT2"(Relay) operates, Lamp is ON
OUT3	When "OUT3"(Relay) operates, Lamp is ON
OUT4	When "OUT4"(Relay) operates, Lamp is ON

3-2-2. Key Operation



	<ol style="list-style-type: none"> 1. Normal Mode : Make Weight value as Zero. (F07, F08 setting) 2. Calibration Mode : Cancel the value or move to previous step. 3. F-Function setting : Cancel 4. Set point setting : Cancel 5. Test Mode 1 : Cancel or move to previous step 6. Test Mode 2 : Cancel or move to previous step 7. Set up Mode : Cancel
	<ol style="list-style-type: none"> 1. Normal Mode : Set the TARE Function .(F09 setting) 1st input : "TARE", 2nd input : "TARE Reset" (When "HOLD" or weight value is ZERO, then this key doesn't work.) 2. Calibration Mode : Move to left 3. F-Function setting : Move to left

SI 580E DIN SIZE WEIGHING CONTROLER

	<p>4. Set point setting : Set SP-1 value</p> <p>5. Test Mode 1 : Analog value check mode</p> <p>6. Test Mode 2 : Relay out check mode</p> <p>7. Set up Mode : Enter F-FUNCTION Mode</p>
	<p>1. To set the "HOLD" Function (refer F10) [1st input : "HOLD", 2nd input : "HOLD Reset"]</p> <p>2. Calibration Mode , F-Function setting : Move to right</p> <p>3. Under "SETUP" Mode, Enter into the "Calibration" Mode.</p> <p>4. Set point setting : Set SP-2 value</p> <p>5. Test Mode 1 : Analog Variation value check mode</p> <p>6. Test Mode 2 : Check relay output</p> <p>7. Set up Mode : Enter Calibration Mode.</p> <p>※ Under HOLD setting first digit as "H"</p>
	<p>1. Normal Mode : Print out (refer F38, F32)</p> <p>2. Calibration Mode , F-Function setting : Increase set value</p> <p>3. Set point setting : Set SP3 value</p> <p>4. Test Mode 1 : Key/Digital Input check mode</p> <p>5. Test Mode 2 : Standard Serial I/F check mode</p> <p>6. Set up Mode : Enter Test Mode.</p> <p>※ If the printer is installed, under "F01-01 setting, when you press this key the current valued is increased. And the current weight is saved and print out, altogether. (Refer to CH.5-4)</p>
	<p>1. Normal Mode : Press this key 4times, within 2secs, enter to "SET-UP" mode.</p> <p>2. Calibration Mode : Enter</p> <p>3. F-Function setting : Save the value go to next step</p> <p>4. Set point setting : Set SP4 value</p> <p>5. Test Mode 1 : Go back to Test mode 2</p> <p>6. Test Mode 2 : Extended Serial I/F check mode</p> <p>7. Set up Mode : Set point setting Mode.</p>

● Setup Mode :It is a mode can SET UP the calibration, Function of SI580E .(refer to CH5. SET UP)

3-2-3. Hot key (with F key)

	<p>Continuous "TARE" setting (From the second TARE setting, use this key)</p>
	<p>If the Printer is installed, You can print out the "Grand-total data". (GRAND-total data can be checked though Print output).</p>

Tip Max. accumulated weighing count : 999,999times
Over 999,999times → return to "0" time
Max. accumulated weight display : 999999999 (g, kg, ton)
Over 999,999,999 (g, kg, ton) → return to "0" (g, kg, ton)

SI 580E DIN SIZE WEIGHING CONTROLLER

3-3 Rear Panel

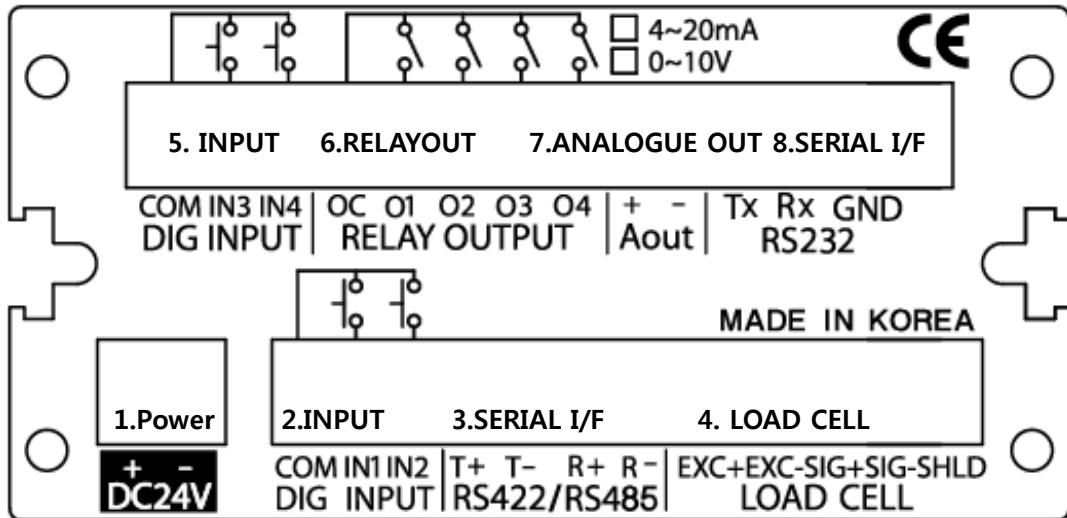

1. Power AC IN: 18V~24V (Power : 24V 1A recommended)
2. External Input terminal: Standard tow port (Refer to F-Function F14, F15, F16, F17 to select desired function of each input terminal)
3. Serial Interface terminal : Port No.1, Bottom side

Communication Method	TX+ Terminal	TX- Terminal	RX+ Terminal	RX- Terminal
RS – 422(Standard)	TX+	TX-	RX+	RX-
RS – 485(Standard)	Not used	Not used	RTX +	RTX-
RS – 232(option)	Not used	Not used	TX	RX

4. Load cell Input

EXC+	EXC-	SIG+	SIG-	SHIELD
------	------	------	------	--------

5. External Input terminal : additional 2pcs digital inputs are on the top (refer to F16, F17) Standard + Extended Digital Inputs are 4 pcs.

6. Relay Output terminal

RELAY COM	RELAY 1	RELAY 2	RELAY 3	RELAY 4
-----------	---------	---------	---------	---------

(Output Mode will be determined by F21-Weighing Modes)

7. Analogue Output terminal (Selectable)

4~20mA (Factory Default)	+	-
0~10V	+	-

8. Serial Interface terminal (port No,2 top side)

Communication	1(from left)	2	3	4
RS – 232C(Standard)	TX+	RX-	GND	GND
RS – 485(option)	RTX+	RTX-	Not used	Not used
RS – 422(option)	TX	TX	RX+	RX-



Please check the Comm. and other specification in the label, attached on the cover plate first, and make connection according to that information.

4. INSTALLATION

4-1. External Dimension & Cutting Size



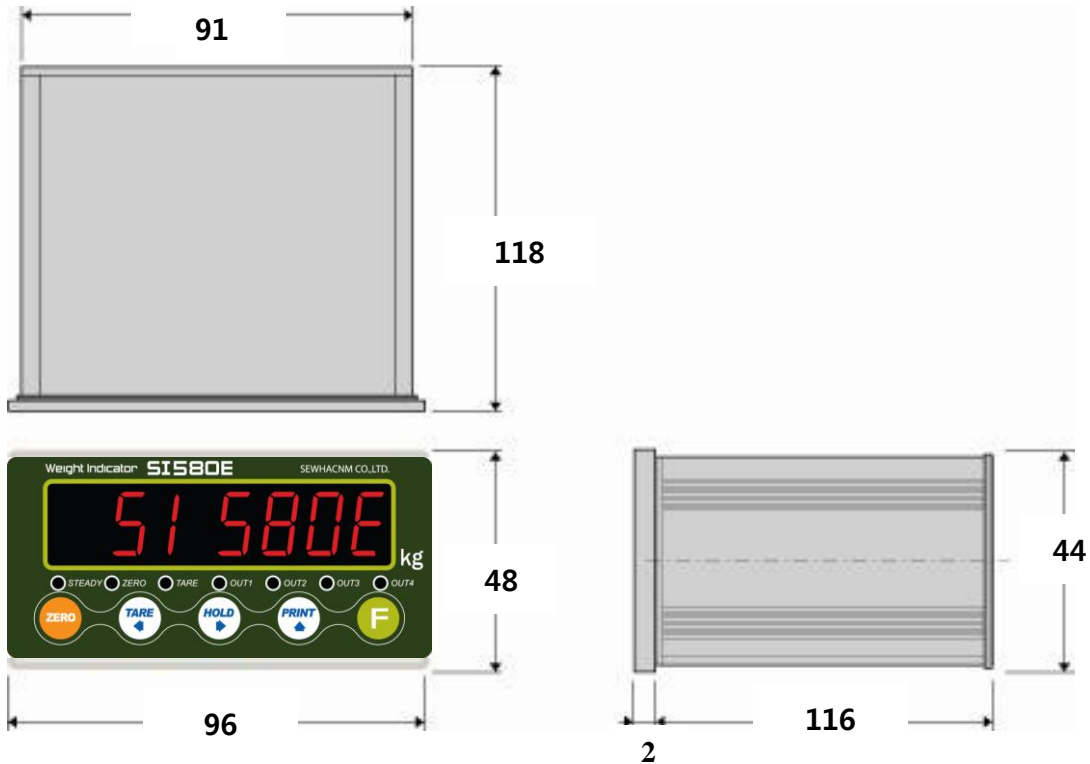

External Dimension (mm)

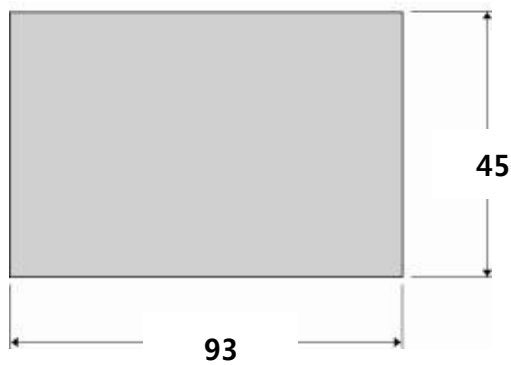

Cutting Size (mm)



4-2. Installation Components

			
SI580E	Connector (5EA) 3P, 5P, 7P x 3	Pin terminal(15EA)	User Manual

SI 580E DIN SIZE WEIGHING CONTROLER

4-3. Load cell Installation

Load Cell Wire Connection (In case of SEWHACNM's Load cell)

It depends on the manufacturer of load cell, please check the specification.

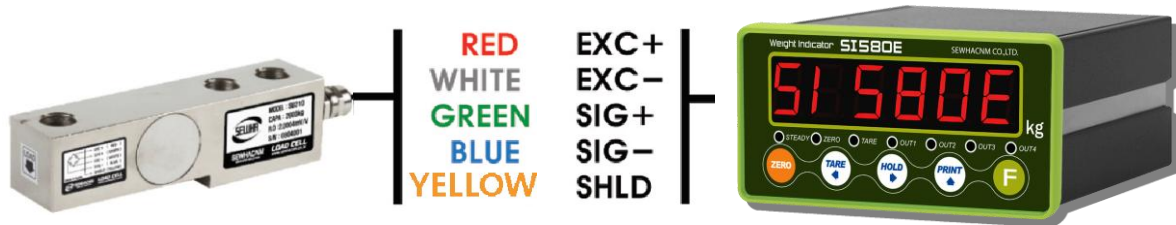

-----Sewhacnm Co.,ltd. Load cell & wire color-----

※ Load cell wire color can be changed without prior notice.



Caution Under set up the Load cell, if EXC+ and EXC- have a short circuit, It may cause damage in the indicator.(specially analogue board)
If you connect other wires to Load cell terminal wrongly, it may cause damage in the analogue board.
Before connecting the load cell cable you have to power off and be sure to connect the cable to the terminal correctly.
Do not weld near the load cells , Indicators or other devices.

■ Installation The Load cells

- 1.You can connect Max. 8pcs of same capacity Load cells at once. (350 Ω)
- 2.You have to make horizontal balance on the ground.
- 3.If you install more than 2pcs of load cells, use Summing box and adjust output signal difference as minimum. It can make wrong weighing process caused by each load cell's variation.
- 4.If there is some temperature difference around Load cell, it can cause wrong weight measurement.
- 5.Don't do Welding job or Arc discharge around installation place. But, there is no choice, please disconnect power cable and Load cell cable.
- 6.If you measure static electricity material, please make earth between down part and up part of Load cell.

5. SET-UP

5-1. Set up

This is the Menu which can set the all of the functions.

There may be some display differences between real and on the manual.

5-1-1. Start "SET UP" Mode (Pass is Word Not used)

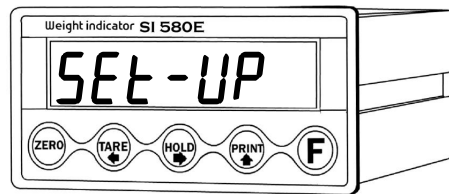
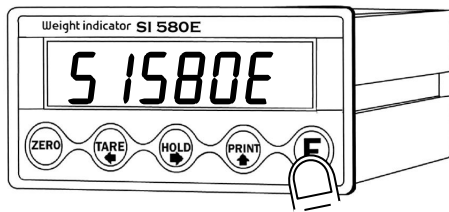

Press  key four times within 2sec

"SET UP" will be displayed, Mode activated

● Start "SET UP" Mode (If Lock function activated– Refer F-function 95)

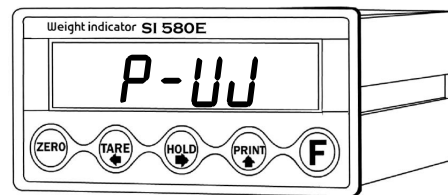
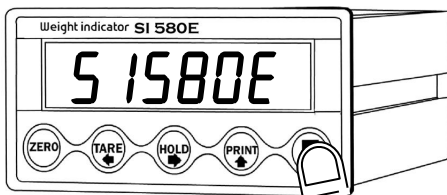

Press  key four times within 2sec

If "P-W" displays, input 4 characters password.

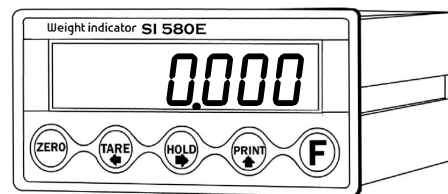
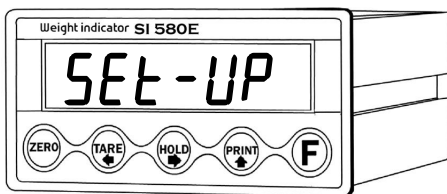

If Password is right, "SETUP" Mode starts. If Password is wrong, back to weighing display.



If you set password by "F95". "TEST" mode, you cannot start "SETUP" Mode without password.

Please don't forget the pass word.









































After starting "Calibration" mode, and "Test" mode, serial I/F will be closed.

● After initialization (F77) the password is



SI 580E DIN SIZE WEIGHING CONTROLLER

To Go Each Mode

Calibration	Weight Calibration	 key 4 times → Pass word →  → 
	Simulation Calibration	 key 4 times → Pass word →  →  → 
F-FUNCTION Mode		 key 4 times → Pass word → 
Test Mode1	Analog Value	 key 4 times → Pass word →  → 
	Analog difference	 key 4 times → Pass word →  → 
	Key test	 key 4 times → Pass word →  → 
Test Mode2	Relay Output	 key 4 times → Pass word →  →  → 
	Analog Output	 key 4 times → Pass word →  →  → 
	Standard Serial I/F	 key 4 times → Pass word →  →  → 
	Extended Serial I/F	 key 4 times → Pass word →  →  → 
Set Value	Set Target	 key 4 times → Pass word →  → 
	Set Free Fall	 key 4 times → Pass word →  → 

● Entering  means **ESC/UPPER step**, Entering  means **SAVE/NEXT Step**.

SI 580E DIN SIZE WEIGHING CONTROLER

■ Adjusting "ZERO" Balance (Calibration)

Adjust weight balance between "Real weight" on the load cell(Weight Part) and "Displayed weight of Indicator". When you replace LOAD CELL or Indicator, you have to Calibrate process once again.

(When you start calibration mode, TARE, HOLD & PRINT will be reset.)



Before processing calibration, please warm up the indicator during 15 min to guarantee more preciseness.

Calibration Key



CANCEL/BACK

Move to left

Move to right

Increase set value

Save and Move
to next step

5-2 Test Weight Calibration Mode (Using test weight)

5-2-1. Start Test Weight Calibration Mode

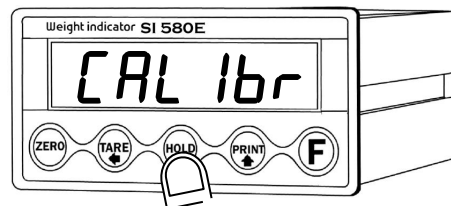
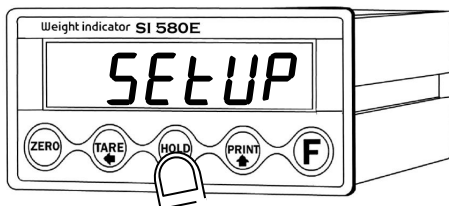

Under "SETUP" displays then Press



key.

When "CALIBR" displays, press



key,

Then Test Weight Calibration Mode starts.

※ If you set password through "F95", you have to input the pass word.

SI 580E DIN SIZE WEIGHING CONTROLLER

5-2-2. Setting "Capacity of weighing Scale"

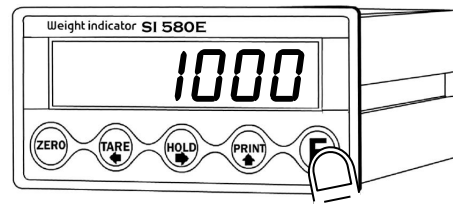
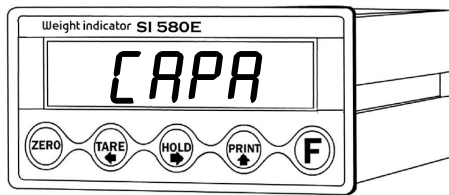

After displaying "CAPA", input max capacity with keys & Press  key to save & move to next step.

Tip If you want that set Max capa is 1,000kg, then just input "1000".

5-2-3. "Decimal Point" and "Digit / Division" Value

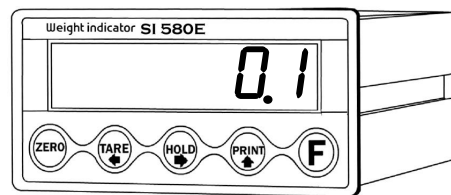
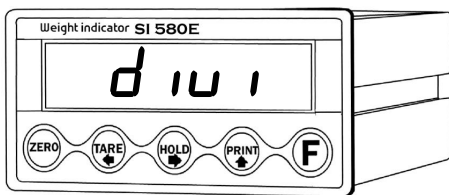

After "DIVI" displays, set Decimal point with  key.

Whenever pressing , Decimal point will be changed.

And set Division values with  key, Finally press  key to save.

Tip

Max. Decimal point will be 0.001, and digit can be selectable among 1, 2, 5, 10, 20, 50.

Digit and Decimal point must be fulfill the below condition.

- (Max. capacity value / division value) cannot be over than 20,000.

If this condition is not fulfilled, "Err-1" will be displayed and move back to Capacity setting mode.

SI 580E DIN SIZE WEIGHING CONTROLER

5-2-4. Measure the "DEAD" Weight of Weighing Scale.

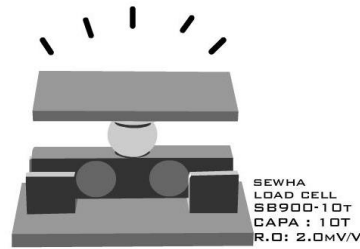
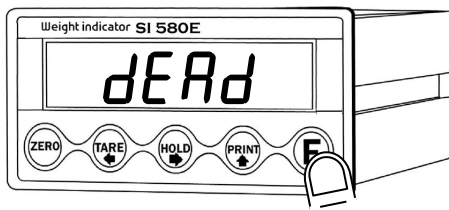

When "DEAD" displays, press  key, then indicator will calculate Dead weight of scale part automatically.

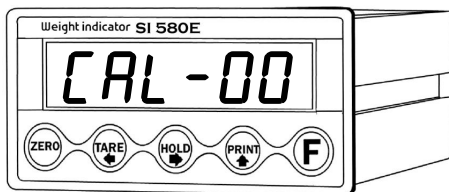

Indicator will search "DEAE weight" during 10~20 secs automatically to find the best condition.

※ Over than 1/10,000 resolution setting,
To guarantee the preciseness, DEAD weight calculation (CAL00~CAL09) will be operated twice.

Tip

In this step, if there is some force or Vibration on scale part, these unstable conditions will be continued, "ErrorA" will be displayed, and "DEAD value" will not be calculated. Under this condition, please remove the cause of force or vibration and process it again.

5-2-5. Input Test Weight value and Calculate SPAN value.

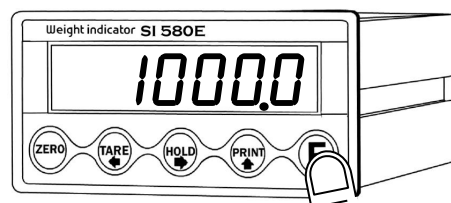
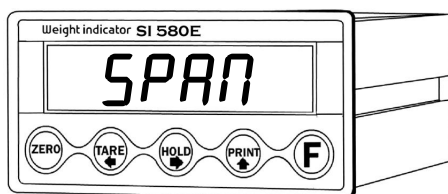

If "SPAN" is displayed, input "Test Weight" capacity and press  key.



SI 580E DIN SIZE WEIGHING CONTROLLER

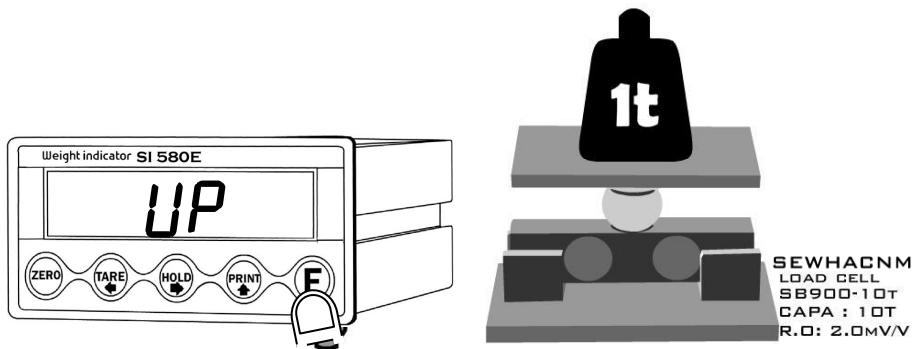

If "UP" is displayed, please load "Test Weight" on the scale part and press  key.

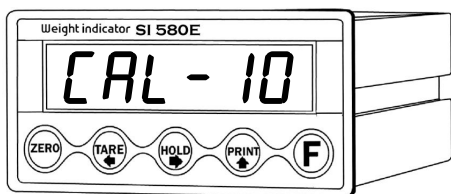

Calculate Span value during 10 ~20 secs, automatically.

※ Over than 1/10,000 resolution setting,
To guarantee the preciseness, Span calculation will be operated twice.

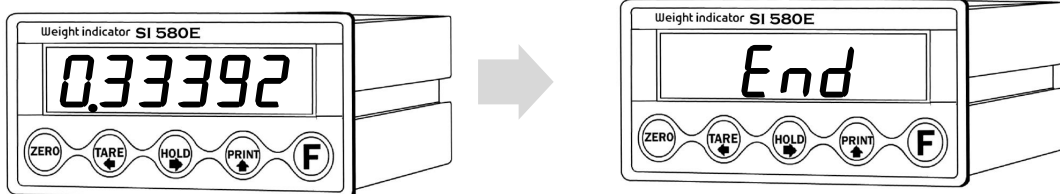

After calculation, span value will be displayed on

the display. Then press  key.

※This span value is not a weight value.

When " END" is displayed and calibration is completed.

SI 580E DIN SIZE WEIGHING CONTROLER

5-3. Simulation Calibration Mode(Calibrate without Test weight)

With this "Simulation Calibration Mode" you can make simple calibration without any "TEST weight"

This calibration mode uses "Load cells' max capacity" and "Max. Output Rate(mV)", so the weight adjustment degree might be less than "Test weight Calibration".

The guaranteed resolution of this "Simulation Calibration" is 1/3,000.

5-3-1. Simulation Calibration Mode Start

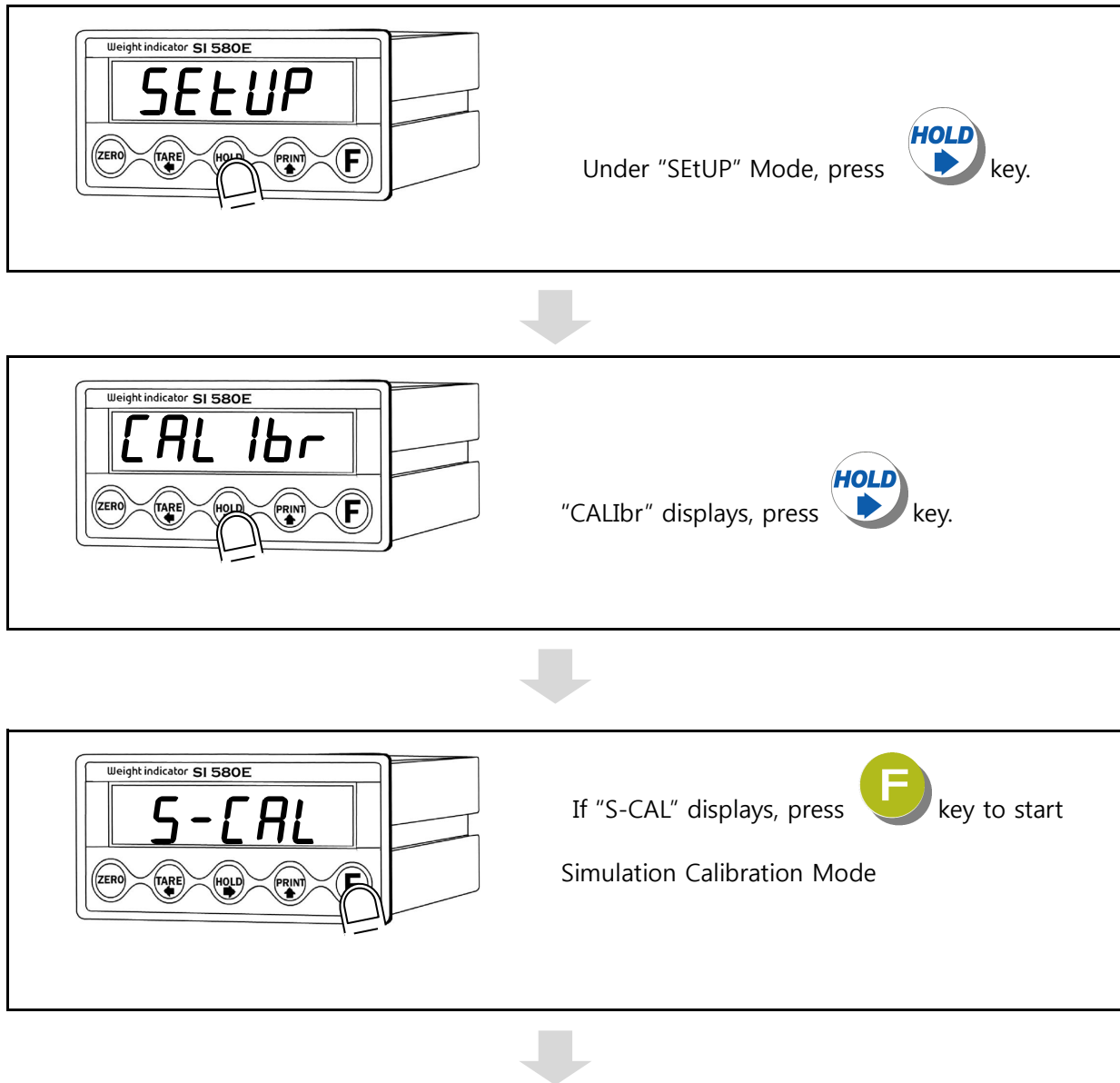

SI 580E DIN SIZE WEIGHING CONTROLLER

5-3-2. Setting "Capacity of Load Cell"

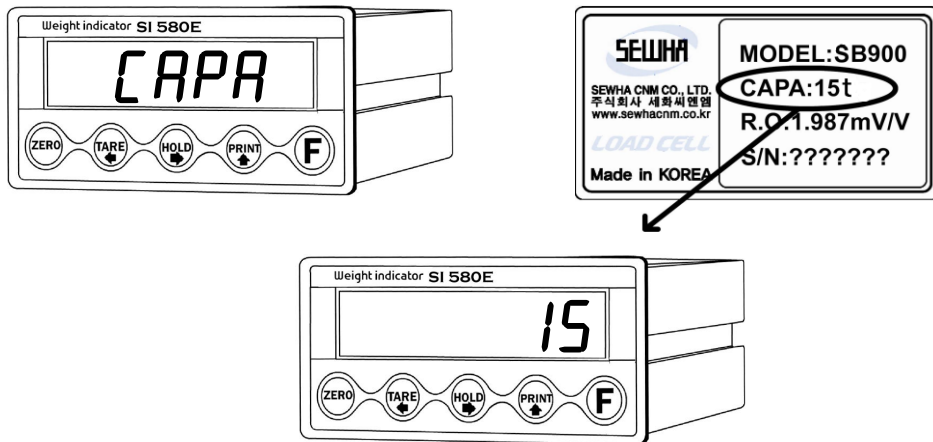



After "CAPA" displayed, Check Max. Capacity of Load cell.
(refer the load cell label, or Test Report)

Input the Max. Capacity of Load cell. And press  key.

Tip In case of plural piece of load cells are installed, Please make sum of each load cell's capacity and make setting with Max. Capacity.
EX) There are 4pcs of load cells, and each load cell's Max. capa is1,000kg.
Then, total Max. Capacitywill be 4,000kg(1,000 x 4) and you have to input 4,000.

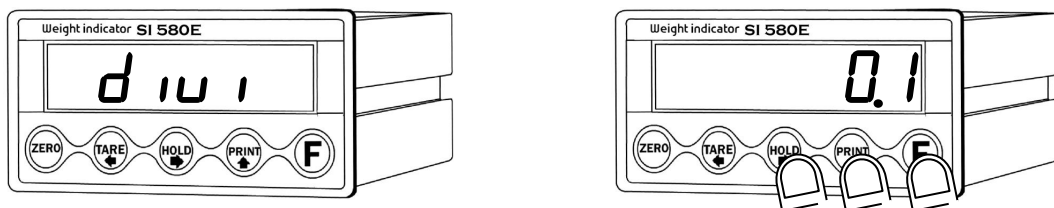
5-3-3. Setting "Digit / Division" value



After "DVI" is displayed select Decimal point with  key.

Whenever pressing  key , decimal point will be changed.

Please stop at the optimal position. And select Division optimal division with  key.

Finally press  key to save and move to next step.

SI 580E DIN SIZE WEIGHING CONTROLER

5-3-4. Measure the "DEAD Weight" of Weighing Scale.

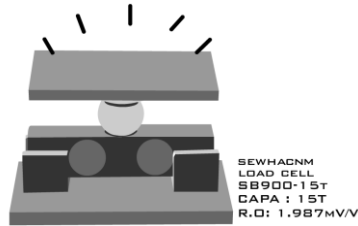
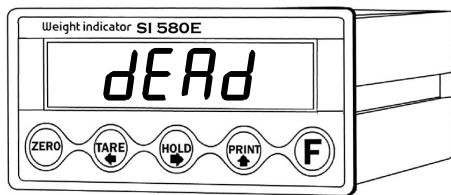

"dEAd" is displayed. Please press **F** key with empty scale.

Then the indicator starts to measure and find optimal "Dead weight value of Scale" automatically.

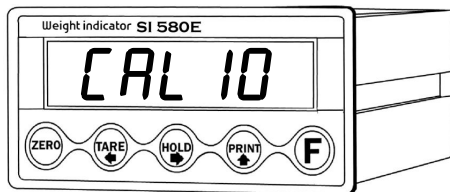

It takes 10sec or 20sec to get the best situation.

Over than 1/10,000 resolution setting,

To guarantee the preciseness, dead weight calculation will be operated twice.

5-3-5. Input Max. Output (Rated Output Voltage / mV)

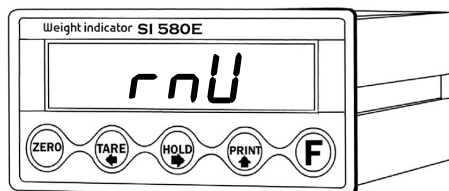

Input the output value load cell
Following fixed decimal point.

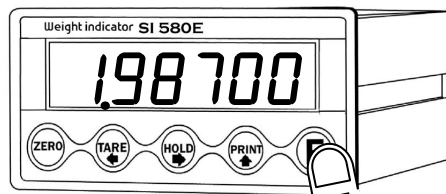

After "CAPA" displayed, Check Max. Capacity of Load cell.

(refer the load cell label, or Test Report) . Press **F** key to save and move to next step.

SI 580E DIN SIZE WEIGHING CONTROLER

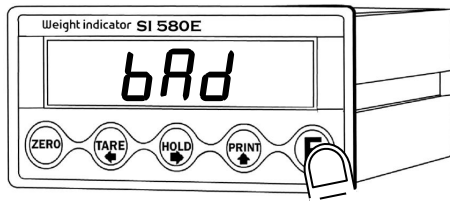

If input wrong value, there will display "BAD", please go back to *Setting "Capacity of Load Cell"*.

After recheck the label of load cell and retry the process.

After displaying "mV", input Load cell Output Rate(mV), referring the load cell label. And press



key to save.

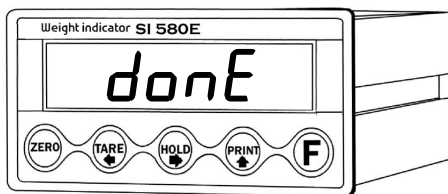

After finishing calculation, calculated "Span value" will be display with "DONE"

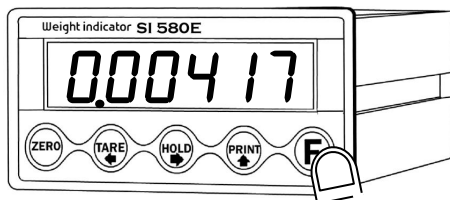

Now, the Simulation Calibration is done, press



key to complete the calibration process.

Tip

In case of plural piece of load cells are connected, the rated output will be same as single load cell's. (Because plural load cells are connected with parallel connection, the sum of rated output voltage is same as single load cell's rated output)

※Due to some variation between "**State output rate**" and "**Real Output rate**" of load cell, there might be some weight difference after finishing calibration.

If you want to make more precise weighing process, please measure real output rate of load cell and input the measured value.

Then the weight measurement will be more precise than before.



SI 580E DIN SIZE WEIGHING CONTROLLER

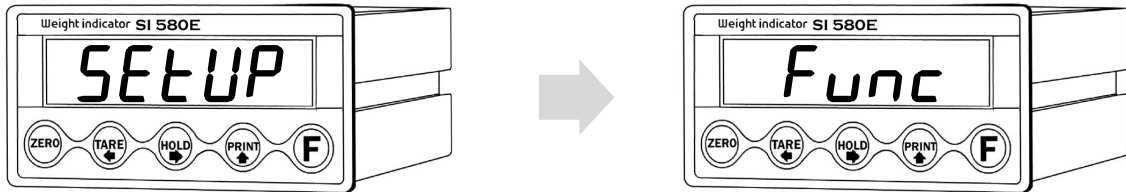

5-4. F-FUNCTION Setting

Set-up means set the F-function and make optimal operation of SI 580E controller.

■ Starting F-FUNCTION Mode



Press  key 4 times → Input Password → Displaying "SETUP" press  key.

The diagram shows the SI 580E controller with the screen displaying 'F01-00'. Three callout boxes provide instructions: 1. 'Make Function No. And Press  key' with an arrow pointing to the F key. 2. 'Whenever press  key, function No. increased.' with an arrow pointing to the PRINT key. 3. 'Set the function no. set value and Press  key' with an arrow pointing to the F key. Below the controller, the buttons are labeled: ZERO (ESC), TARE (LEFT), HOLD (RIGHT), PRINT (INCREASE), and F (SAVE).

Make Function No. And Press  key

Whenever press  key, function No. increased.

Set the function no. set value and Press  key

Weight indicator SI 580E

F01-00

ZERO TARE HOLD PRINT F

ESC LEFT RIGHT INCREASE SAVE

SI 580E DIN SIZE WEIGHING CONTROLER

F-FUNCTION LIST

General Function Setting ("●" Factory default set value)

Weighing Data Save Method selection			
F01	●	0	Non-Save Mode (Weight Data & Frequency)
		1	Save Mode (Weight Data & Frequency)
Weight –Back up selection			
F02		0	Normal Mode
	●	1	Weight Back up Mode
Motion Band Range setting			
F03	05	1~99	This is set "Steady" acceptable range of weighing part. If there is vibration on weighing part, you can set this function and reduce the vibration effect on weighing process. 1 : Weak vibration ~ 99 : Strong Vibration
Zero Tracking Compensation Range setting			
F04	05	0~99	Due to external causes (Temperature, wind, and dust), there will be small weight difference, the Indicator will ignore the weight difference and display as Zero.
Auto Zero Range setting			
F05	00	0~99	Within the "Auto Zero" range, weighing part is steady, indicator will display current weight as "Zero" If the weighing part is not "Steady", indicator will display current weight. (Auto Zero Range : ± Set value + weight unit)
Digital Filter setting			
F06	04	0~40	Weak vibration Strong Vibration 0 (Weak) ~ 40 (Strong)
Zero key Operation mode selection			
F07		0	Activate under "Steady" condition, only
	●	1	Always activate
Zero key Operation Range selection : (-) value is same to (+)			
F08		0	Activated within 2% of Max. Capacity
		1	Activated within 5% of Max. Capacity
	●	2	Activated within 10% of Max. Capacity
		3	Activated within 20% of Max. Capacity
		4	Activated within 50% of Max. Capacity
		5	Activated within 100% of Max. Capacity
		6	No limit of Zero key operation range.

SI 580E DIN SIZE WEIGHING CONTROLER

CAUTION : If setting over than 10%, The display weight could be over than Load cell input signal or Max. Capacity and it may display "CELL-Err" or incorrect weight value. And It can be the cause of load cell damage.						
Tare key Operation Range selection: (-) value is same to (+)						
F09		0	Activated within 10% of Max. Capacity			
		1	Activated within 20% of Max. Capacity			
	●	2	Activated within 50% of Max. Capacity			
		3	Activated within 100% of Max. Capacity			
"Hold" Mode selection						
F10	●	0	Peak Hold : Measure Max. weight value and hold on display.			
		1	Sample Hold : Hold current weight until "Hold Reset"			
		2	Average Hold : Hold average value (Refer F-F54)			
"STEADY" condition check time setting						
F11	03	0 ┆ 99	During the set time period, estimate weighing part's "STEADY" condition and display. If you set small value, indicator will take "STEADY" fast, if you set value, indicator will take "STEADY" slow. (0.5sec per set value)			
Display Up-Date speed setting						
F12	●	1	60/sec	6	6/sec	
		2	30/sec	7	3/sec	
		3	20/sec	8	2/sec	
		4	15/sec	9	1/sec	
		5	10/sec			
Weight Display selection under "Unpass / OverLoad"condition : (-) value is same to (+)						
F13		0	Not Display Weight			
	●	1	Display Weight (with a flash)			
External Input Selection 1 (IN1) – Bottom side Terminal						
F14		0	Not used	7	HOLD/HOLD RESET	
	●	1	ZERO	8	RUN (F21-03 Under Packer Mode)	
		2	TARE	9	STOP (F21-03 Under Packer Mode)	
		3	TARE RESET	10	RUN / STOP(F21-03 Under Packer Mode)	
		4	TARE / TARE RESET	11	PRINT	
		5	HOLD	12	PRINT the amount	
		6	HOLD RESET			

SI 580E DIN SIZE WEIGHING CONTROLER

External Input Selection 2 (IN2) – Bottom side Terminal						
F15		0	Not used		7	HOLD/HOLD RESET
		1	ZERO		8	RUN (F21-03 Under Packer Mode)
		2	TARE		9	STOP (F21-03 Under Packer Mode)
		3	TARE RESET		10	RUN / STOP(F21-03 Under Packer Mode)
	●	4	TARE / TARE RESET		11	PRINT
		5	HOLD		12	PRINT the amount
		6	HOLD RESET			
External Input Selection 3 (IN3) – Top side Terminal						
F16		0	Not used	●	7	HOLD/HOLD RESET
		1	ZERO		8	RUN (F21-03 Under Packer Mode)
		2	TARE		9	STOP (F21-03 Under Packer Mode)
		3	TARE RESET		10	RUN / STOP(F21-03 Under Packer Mode)
		4	TARE / TARE RESET		11	PRINT
		5	HOLD		12	PRINT the amount
		6	HOLD RESET			
External Input Selection 4 (IN4) - Top side Terminal						
F17		0	Not used		7	HOLD/HOLD RESET
		1	ZERO		8	RUN (F21-03 Under Packer Mode)
		2	TARE		9	STOP (F21-03 Under Packer Mode)
		3	TARE RESET		10	RUN / STOP(F21-03 Under Packer Mode)
		4	TARE / TARE RESET	●	11	PRINT
		5	HOLD		12	PRINT the amount
		6	HOLD RESET			
Equipment No. setting – ID No.setting						
F18	01	01~99	ID No. setting with No. key. (01~99 selectable)			

■ Relay Output Mode Setting (refer 5-5. SET-POINT setting)

Weighing Mode Selection			
F21	●	1	Limit Mode 1 : SP1 / SP2 / SP3 / Empty Output Setting
		2	Limit Mode 2. : SP1 / SP2 / SP3 / SP4 Output Setting "A" dry, User's relay
		3	Packer Mode 1 : Target / SP1 / Finish / Empty Output Setting
		4	Packer Mode 2 : Target / SP2 / SP3 / Finish Output Setting
		5	Packer Mode 3 : Target / SP2 / SP3 / Empty Output Setting
		6	Limit Mode 3. : SP1 / SP2 / SP3 / SP4 Output Setting "B" dry , User's relay
		7	Accumulating Mode1 : SP1 / SP2 / SP3 / Finish Output setting
		8	Accumulating Mode2 : SP1 / SP2 / SP3 / SP4 Output setting

SI 580E DIN SIZE WEIGHING CONTROLLER

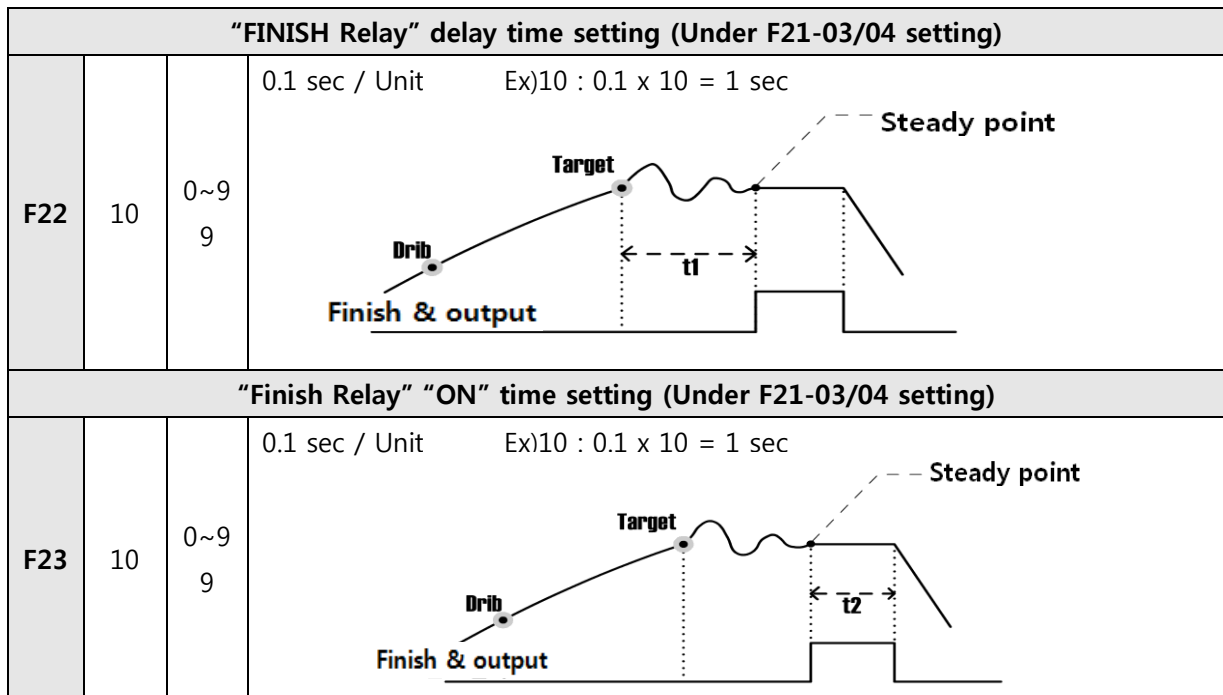

■ Communication Mode Setting – Standard Serial port setting

Parity Bit selection Mode						
F30	●	0	DATA Bit (8 Bit)	STOP Bit (1 Bit)	Parity Bit (Non)	
		1	DATA Bit (8 Bit)	STOP Bit (1 Bit)	Parity Bit (Odd)	
		2	DATA Bit (8 Bit)	STOP Bit (1 Bit)	Parity Bit (Even)	
		3	DATA Bit (8 Bit)	STOP Bit (2 Bit)	Parity Bit (Non)	
		4	DATA Bit (8 Bit)	STOP Bit (2 Bit)	Parity Bit (Odd)	
		5	DATA Bit (8 Bit)	STOP Bit (2 Bit)	Parity Bit (Even)	
		6	DATA Bit (7 Bit)	STOP Bit (1 Bit)	Parity Bit (Odd)	
		7	DATA Bit (7 Bit)	STOP Bit (1 Bit)	Parity Bit (Even)	
		8	DATA Bit (7 Bit)	STOP Bit (2 Bit)	Parity Bit (Odd)	
	9	DATA Bit (7 Bit)	STOP Bit (2 Bit)	Parity Bit (Even)		
Serial Communication Speed selection						
F31		0	2,400bps		5	28,800bps
		1	4,800bps		6	38,400bps
	●	2	9,600bps		7	57,600bps
		3	14,400bps		8	76,800bps
		4	19,200bps		9	115,200bps
DATA Transmission Method selection						
F32		0	Simplex Mode / Stream Mode			
	●	1	Duplex Mode / Command Mode			
		2	Print Mode			

SI 580E DIN SIZE WEIGHING CONTROLER

"Check-Sum" detection selection (Under F32-01 setting, only)			
F34	<input checked="" type="radio"/>	0	Check-Sum Not Use
		1	Check-Sum Use
Under Stream Mode select the way transmit data protocol/frame (basic port)			
F35	<input checked="" type="radio"/>	0	Transmit by Protocol
		1	Transmit by frame (in case of using specific utility)
Caution : In case of "Transmit by frame" & under 14400bps setting(F31), the speed of system will be slow.			
DATA Transference Mode selection (Under F32-00 setting, only)			
F36	<input checked="" type="radio"/>	0	Weighing Data will be transferred continuously
		1	Single time data transference, at first steady point, over than Empty range.
		2	Single time data transference, first weight steady point over than Empty range.
		3	Data transference, Whenever "Print" key input
DATA Transference Format selection (Under F32-00 setting, only)			
F37	<input checked="" type="radio"/>	0	Format 1 (recommended when using external display)
		1	Format 2. (Format 1 + ID No.)
		2	Format 3 (recommended when connecting to PLC or PC)
		3	CAS Format
Print Mode selection (Under F32-02 setting, only)			
F38	<input checked="" type="radio"/>	0	Manual Print : Whenever "Print" key input.
		1	Auto print (at the first Steady point over "EMPTY" range or Whenever "Print" key input.)
		2	Auto print (Whenever Steady status at over "EMPTY" rage or Whenever "Print" key input.)
		3	Auto print : Whenever finish weigh(under F21-3, 4, 5 setting, only)

■ Print Mode Setting

Weight Unit selection			
F41	<input checked="" type="radio"/>	0	Kg
		1	g
		2	t
Print Format selection			
F42	<input checked="" type="radio"/>	0	Continuous Print - Serial No. and Weight will be printed continuously.
		1	Single Print - Date, Time, S/N, ID No. Weighing Data will be print
SUB/GRAND Total Data Delete selection			
F44	<input checked="" type="radio"/>	0	Not deleted (manual Delete mode)
		1	Automatically Deleted.-After print out SBU/GRAND Total.

SI 580E DIN SIZE WEIGHING CONTROLER

Paper Withdraw Rate setting (After SUB/GRAND Total Print)			
F45	3	0~9	Whenever set value increased, 1 line will be added.
Paper Withdraw Rate setting (After Continuous/Single Print)			
F46	3	0~9	Whenever set value increased, 1 line will be added.
Printing Language Selection			
F47	●	0	KOREAN
		1	ENGLISH
Minus(-) symbol Print selection			
F49	●	0	Print minus(-) symbol, if the weight is minus(-).
		1	Ignore minus(-) symbol

■ Extended Function Setting

Analogue Output Setting (4~20mA / 0~10V)			
F50	●	0	Positive Output (Max. Capacity : 20mA output)
		1	Negative Output (Max. Capacity : 4mA output)
Analogue Output Selection (20mA or 10V output point selection)			
F51	●	0	Max. Capacity : 20mA or 10V will be output
		1	SP1 set point : 20mA or 10V will be output
		2	SP2 set point : 20mA or 10V will be output
		3	SP3 set point : 20mA or 10V will be output
		4	SP4 set point : 20mA or 10V will be output
"NEAR ZERO" relay output mode selection			
F53	●	0	Display weight is Zero → Near Zero relay output
		1	Only Gross Zero(Net weight + TARE) → Near Zero relay output
Set time of "Average Hold"			
F54	3	0~9	When setting "Average Hold", set the time. (unit : sec) ※Automatic Hold Reset , After set time

■ Communication Mode Setting – Extended Serial Interface setting.







Parity Bit selection Mode(Extended Serial port)					
F60	●	0	DATA Bit (8 Bit)	STOP Bit (1 Bit)	Parity Bit (Non)
		1	DATA Bit (7 Bit)	STOP Bit (2 Bit)	Parity Bit (Non)
		2	DATA Bit (7 Bit)	STOP Bit (1 Bit)	Parity Bit (Even)
		3	DATA Bit (7 Bit)	STOP Bit (1 Bit)	Parity Bit (Odd)
		4	DATA Bit (8 Bit)	STOP Bit (2 Bit)	Parity Bit (Non)
		5	DATA Bit (8 Bit)	STOP Bit (1 Bit)	Parity Bit (Even)
		6	DATA Bit (8 Bit)	STOP Bit (1 Bit)	Parity Bit (Odd)

SI 580E DIN SIZE WEIGHING CONTROLER

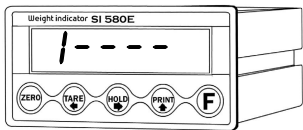
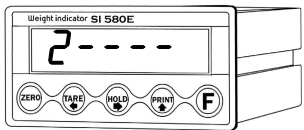
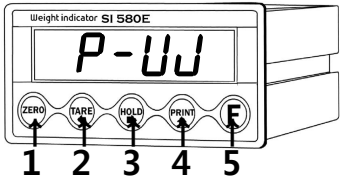
Serial Communication Speed selection(Extended Serial port)					
F61	0	2,400bps	5	28,800bps	
	1	4,800bps	6	38,400bps	
	<input checked="" type="radio"/>	2	9,600bps	7	57,600bps
	3	14,400bps	8	76,800bps	
	4	19,200bps	9	115,200bps	
DATA Transference Method selection(Extended Serial port)					
F62	<input checked="" type="radio"/>	0	Simplex Mode / Stream Mode		
	1	Duplex Mode / Command Mode			
	2	Print Mode			
"Check-Sum" detection selection (Under F62-01 setting, only)					
F64	<input checked="" type="radio"/>	0	Check-Sum Not Use		
	1	Check-Sum Use			
Under Stream Mode select the way transmit data protocol/frame (extended port)					
F65	<input checked="" type="radio"/>	0	Transmit by Protocol		
	1	Transmit by frame (in case of using specific utility)			
Caution : In case of "Transmit by frame" & under 14400bps setting(F61), the speed of system will be slow.					
DATA Transference Mode selection (Extended Serial port)					
F66	<input checked="" type="radio"/>	0	Weighing Data will be transferred continuously		
	1	Single time data transference, Whenever the weight is steady over than Empty range.			
	2	Single time data transference, first weight steady point over than Empty range.			
	3	Data transference, Whenever "Print" key input			
DATA Transference Format selection (Extended Serial port)					
F67	<input checked="" type="radio"/>	0	Format 1 (recommended when use external display)		
	1	Format 2. (Format 1 + ID No.)			
	2	Format 3.			
	3	CAS Format			
Print Mode selection (Extended Serial port)					
F68	<input checked="" type="radio"/>	0	Manual Print : Whenever "Print" key input.		
	1	Auto print (When the first Steady point over "EMPTY" range or Whenever "Print" key input.)			
	2	Auto print (Whenever Steady status at over the range of "EMPTY" or Whenever "Print" key input.)			

SI 580E DIN SIZE WEIGHING CONTROLLER

Other Setting Mode

EMPTY Range setting		
F80	10	You can set "EMPTY" Range. Ex) "0" setting : When Net Zero, "Zero" status lamp is ON. "200" setting : Under "200", "Zero" Status lamp is ON.
Minimum Analog Output Setting		
F81		You can set the minimum analog output setting (4~20mA/0~10V).
Maximum Analog Output Setting		
F82		You can set the maximum analog output setting (4~20mA/0~10V).
TIME(H,M,S) Check / Change (24Hours)		
F90		Check Current DATE data or you can Change to new date
DATE(Y,M,D) Check / Change		
F91		Check Current TIME data or you can Change to new time
SETUP Mode Password Key Setting / Change		
F95	Setting the password	
	 	
	<p>1) When "1" displays, input 4 numbers</p> <p>2) If "2" display, input the 4 numbers once more. (recheck the password)</p>	
Change the password		
		If "P-W" display, input the previous saved password . And set the "FFFF" as New password.
Deactivate Lock setting		
 If you set password four times of  (5555), it is unlocked.		
After initialization (F77) the default password is    		
When setting password you cannot start "SETUP" mode without password, do not forget your password.		
Program & Hard ware Version Check		
F98		Check the Program & Hard ware version Ex) "100 1.04" means H/W : ver.1.00 & S/W : ver.1.04

SI 580E DIN SIZE WEIGHING CONTROLLER

5-5. SET-POINT Setting

(Each Control Relay Set point Value setting- Refer 21)

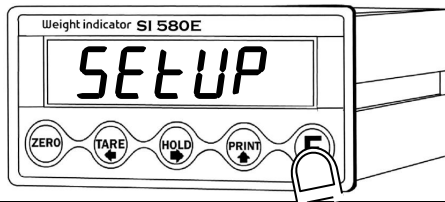

Input **F** key for times → Enter Pass word → Displaying "SETUP" → Input **F** key

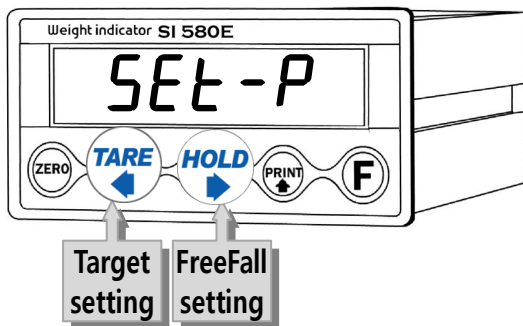

When displaying "SET-P"

Press **TARE** key to enter Target setting mode

Press **HOLD** key to enter FreeFall setting mode

5-5-1. TARGET setting

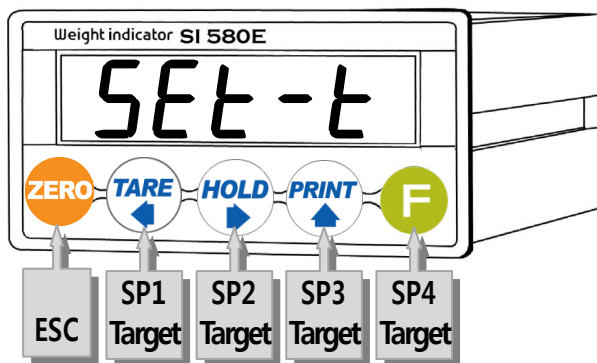

5-5-1. Free Fall setting

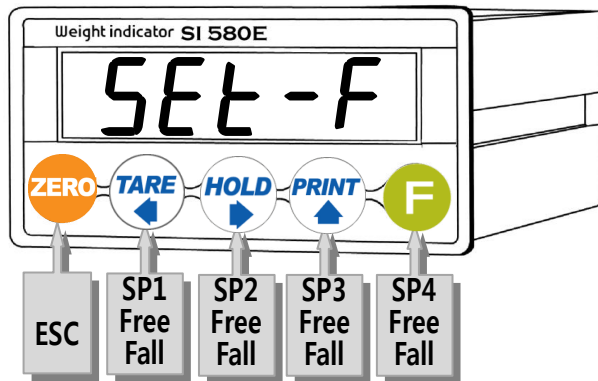

- Free fall setting mode can be set only weighing mode F21 -1, F21-2, F21-6, F21-7, F21-8.
- Free fall value < Target value, If you set wrongly, "Err-B" shows.
- Default Free fall value is "0".
- **ZERO** key means ESC/going to previous step , **F** key means SAVE.

SI 580E DIN SIZE WEIGHING CONTROLLER

◆ Weighing Mode 1 – Limit Mode 1 (F21 – 01 Setting)

– Relay “ON” when weight reaches set value

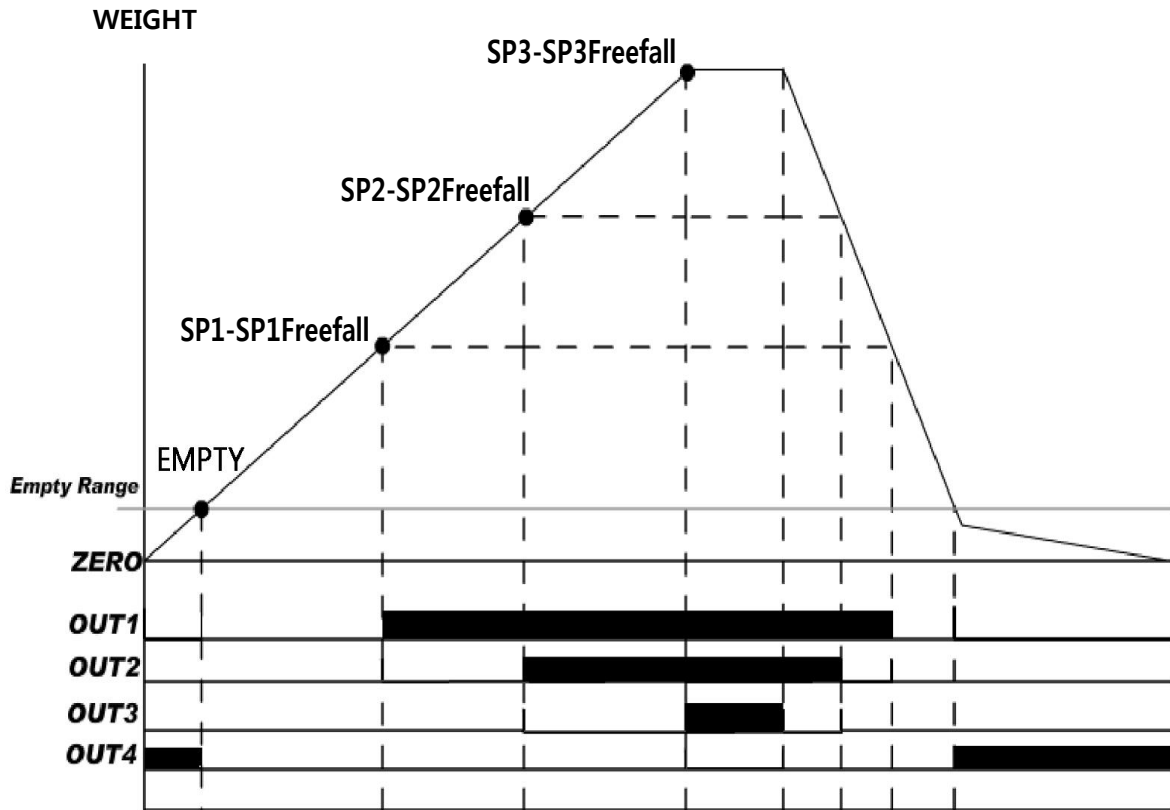

Relay Output

Relay	Contents	Relay	Contents
OUT 1	Current weight \geq SP1-SP1 freefall(ON) Current weight $<$ SP1-SP1 freefall (OFF)	OUT 2	Current weight \geq SP2-SP2 freefall(ON) Current weight $<$ SP2-SP2 freefall(OFF)
OUT 3	Current weight \geq SP3-SP3 freefall(ON) Current weight $<$ SP3-SP3 freefall(OFF)	OUT 4	Within “EMPTY” range “ON” (Refer F80)

- The weight will be measured with absolute value, it doesn't matter +/-.
- Free fall setting mode can be set only weighing mode F21 -1, F21-2, F21-6, F21-7, F21-8.
- Free fall value $<$ Target value, If you set wrongly, “Err-B” shows.
- Default Free fall value is “0”.

SI 580E DIN SIZE WEIGHING CONTROLER

◆ Weighing Mode 2 – Limit Mode 2 (F21 – 02 Setting)

– Relay “ON” when weight reaches set value. User’s relay, “A” dry

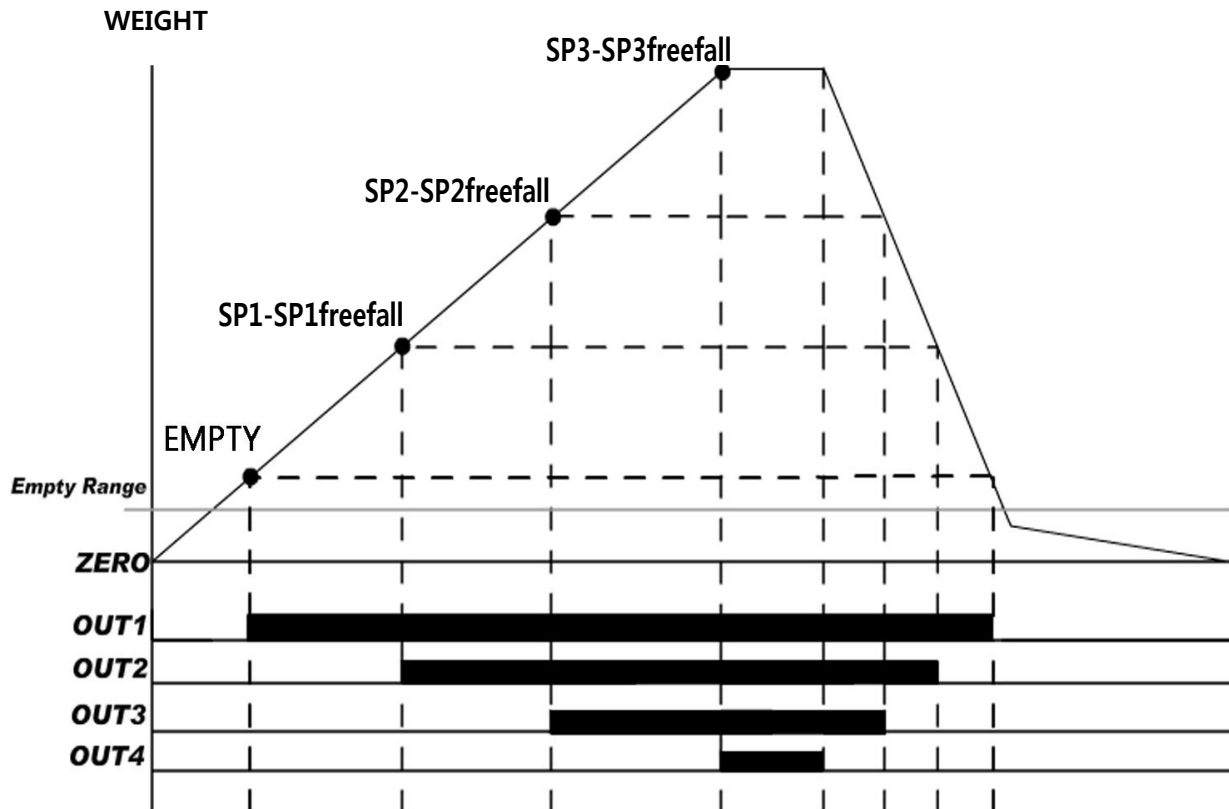

Relay Output

Relay	Contents	Relay	Contents
OUT 1	current weight \geq SP1-SP1 freefall(ON) current weight $<$ SP1-SP1 freefall(OFF)	OUT 2	current weight \geq SP2-SP2 freefall(ON) current weight $<$ SP2-SP2 freefall(OFF)
OUT 3	current weight \geq SP3-SP3 freefall(ON) current weight $<$ SP3-SP3 freefall(OFF)	OUT 4	current weight \geq SP4-SP4 freefall(ON) current weight $<$ SP4-SP4 freefall(OFF)

- The weight will be measured with absolute value, it doesn't matter +/-.
- Free fall setting mode can be set only weighing mode F21 -1, F21-2, F21-6, F21-7, F21-8.
- Free fall value $<$ Target value, If you set wrongly, "Err-B" shows.
- Default Free fall value is "0".

SI 580E DIN SIZE WEIGHING CONTROLLER

◆ Weighing Mode 3 – Packer Mode 1

2 Step control Packer Mode -F21 – 03 Setting

– Relay “ON” when weight reaches set value

- Relay “ON” Within “EMPTY” range

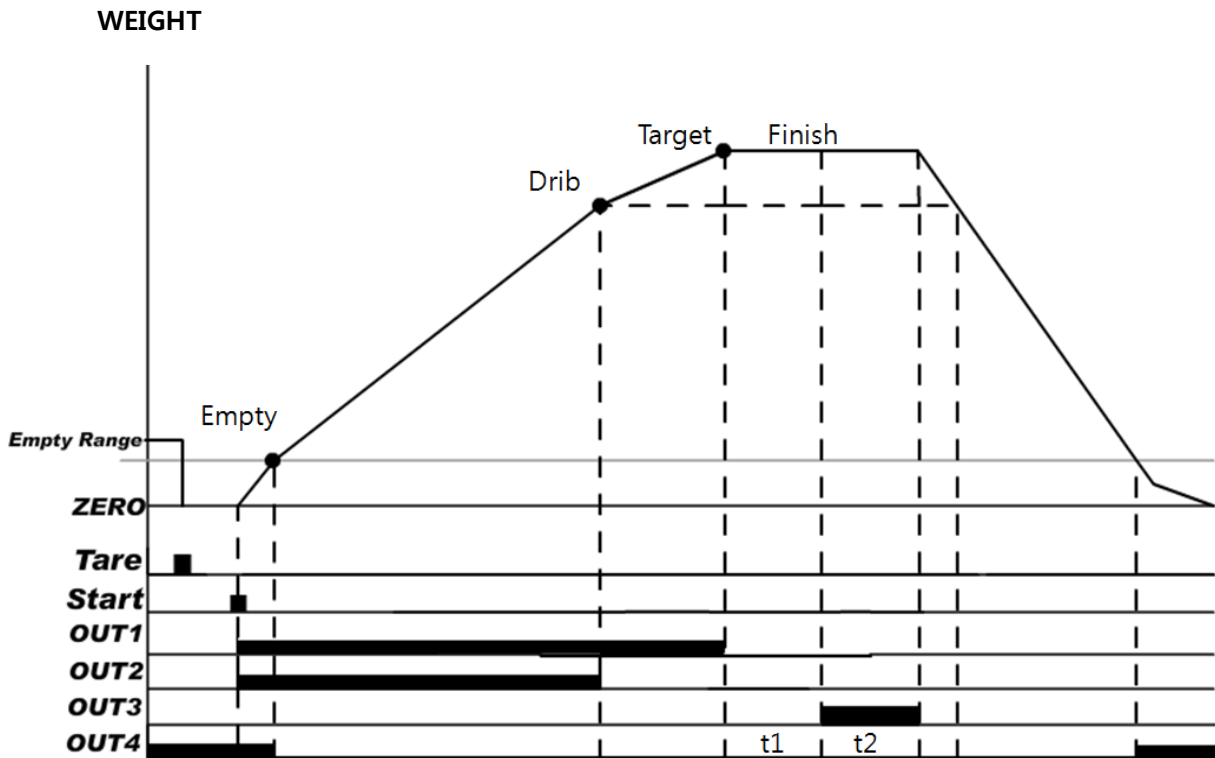

Ex) When input set value as SP1(Target) = 1000, SP2(Drib) = 200, Empty range = 10, SP3(free fall) = 0

Start input : SP1, SP2 and SP4 will be “ON”. Empty Range ≥ 10 , SP4 will be “OFF”.

Current weight will be reaches to (SP1-SP2=800) value, SP2 will be “OFF”.

Current weight will be reaches to SP1, (SP1-SP3=990) , SP1 will be “OFF”.

SP3 will be “ON” after SP1 off and delay during the “t1” time.

※T1 = Finish Relay Output delay time, T2= Finish Relay output duration time

Relay Output

Relay	Contents	Relay	Contents
OUT 1 (Target)	Input “RUN” : “ON” Current weight = Target - SP3 “OFF”	OUT 2 (Drib)	Input “RUN” : “ON” Current Weight = Target – SP2 “OFF”
OUT 3 (Finish)	After reaching target value After “t1” time, “ON” during “t2” time	OUT 4 (Empty)	Within “EMPTY(F80 settin g)” range “ON”

※ The weight will be measured with absolute value, it doesn't matter +/-.

SI 580E DIN SIZE WEIGHING CONTROLLER

◆ Weighing Mode 4

– 3 Steps (F21 – 04 Setting) , Relay "ON" at finish point

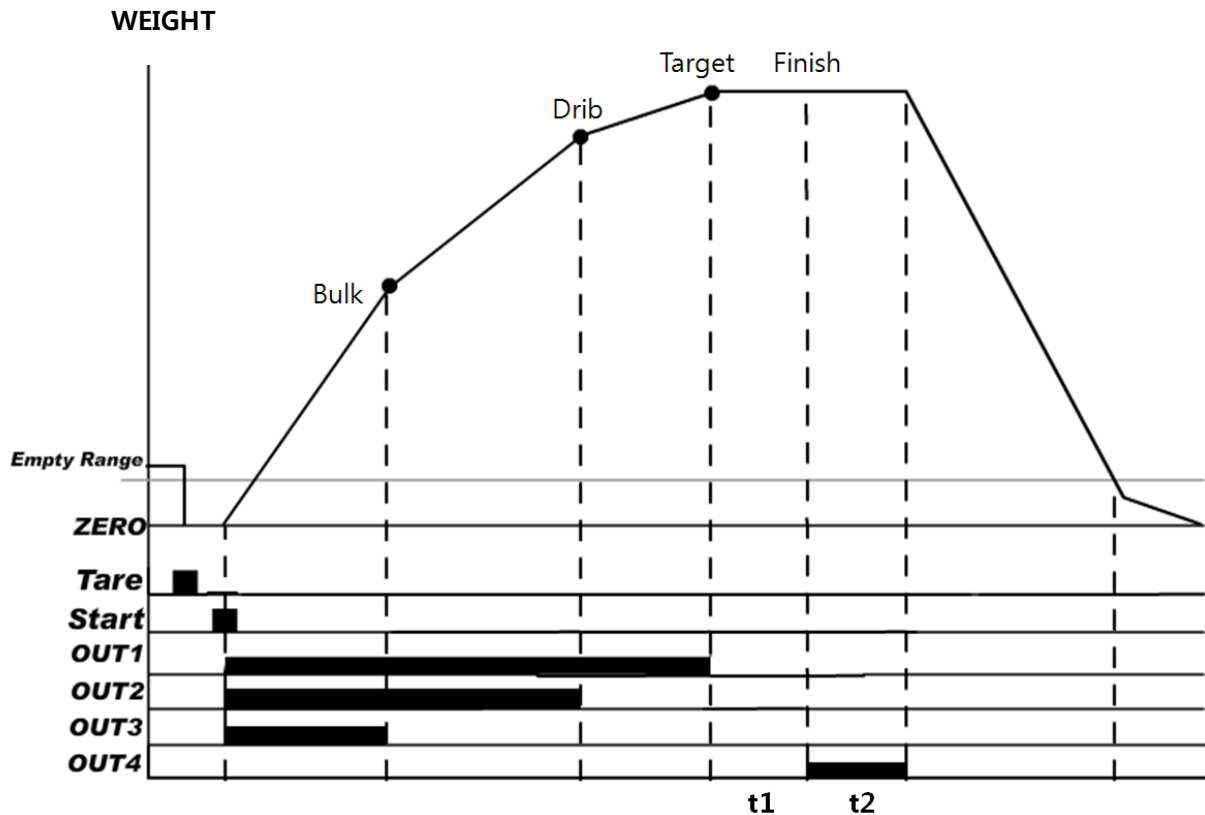

EX) SP1(Target) = 1000, SP2(Drib) = 200, SP3(Bulk) = 500, SP4(Finish)= 50

Start Input : SP1, SP2,SP3 will be "ON"

Current weight will reaches to 500(SP1-SP3), SP3 will be "OFF".

Current weight will reaches to 800(SP1-SP2), SP2 will be "OFF".

Current weight will reaches to 950(SP1-SP4), SP1 will be "OFF".

SP4(Finish) will be "ON", after SP1 relay Off and delay during "t1" time setting.

When Out3 is "ON", the weight value is saved.

※T1 = Finish Relay Output delay time, T2= Finish Relay output duration time

Relay Output

Relay	Contents	Relay	Contents
OUT 1 (Target)	Input "RUN" : "ON" Current weight = Target – SP1: "OFF"	OUT 2 (Drib)	Input "RUN" : "ON" Current weight = Target-SP2 "OFF"
OUT 3 (Bulk)	Input "RUN" : "ON" Current weight = Target-SP3 "OFF"	OUT 4 (Finish)	After reaching target value After "t1" time, "ON" during "t2" time

※ The weight will be measured with absolute value, it doesn't matter +/-.

SI 580E DIN SIZE WEIGHING CONTROLLER

◆ Weighing Mode 5 – Packer Mode 3

3 Steps Control Packer Mode (F21 – 05 Setting), Relay "ON" at Empty range

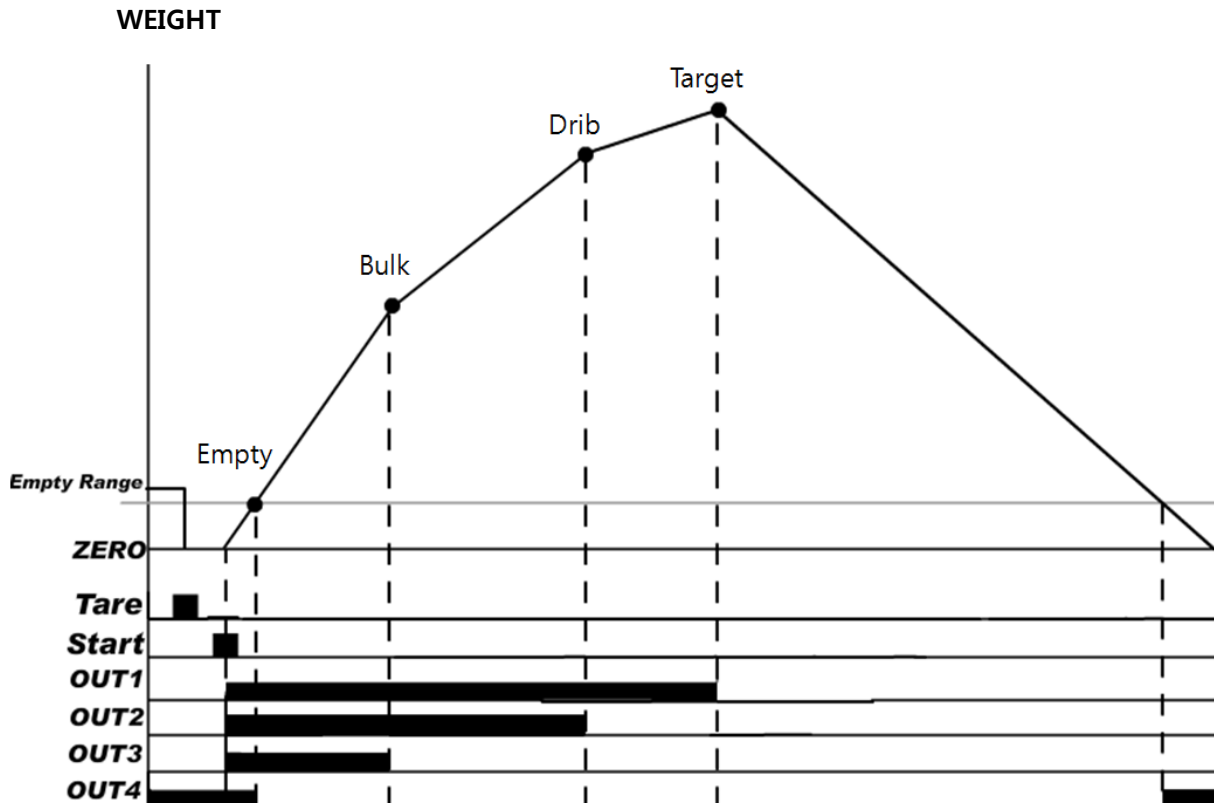

EX) SP1(Target) = 1000, SP2(Drib) = 200, SP3(Bulk) = 500, SP4(Finish) = 50, Empty Range=10

Start Input : SP1, SP2, SP4 will be "ON".

Current Weight reaches to Empty range(=10) , SP4 will be "OFF".

Current Weight reaches to 500(SP1-SP3), SP3 will be "OFF".

Current Weight reaches to 800(SP1-SP2), SP2 will be "OFF".

Current Weight reaches to 950(SP1-SP4), SP1 will be "OFF".

Within the Empty Range again, SP4 will "ON" .

When Out is "OFF", the weight value is saved.

Relay Output

Relay	Contents	Relay	Contents
OUT 1	Input "RUN" : "ON"	OUT 2	Input "RUN" : "ON"
(Target)	Current weight =Target – SP1 : "OFF"	(Drib)	Current weight =Target -SP2 : "OFF"
OUT 3	Input "RUN" : "ON"	OUT 4	Within "EMPTY"(F80 setting) range
(Bulk)	Current weight = Target-SP3 : "OFF"	(Empty)	"ON"

※ The weight will be measured with absolute value, it doesn't matter +/-.

SI 580E DIN SIZE WEIGHING CONTROLER

◆ Weighing Mode 6 – Limit Mode 3 (F21 – 06 Setting)

– Relay “ON” when weight reaches set value. User’s relay, “B” dry

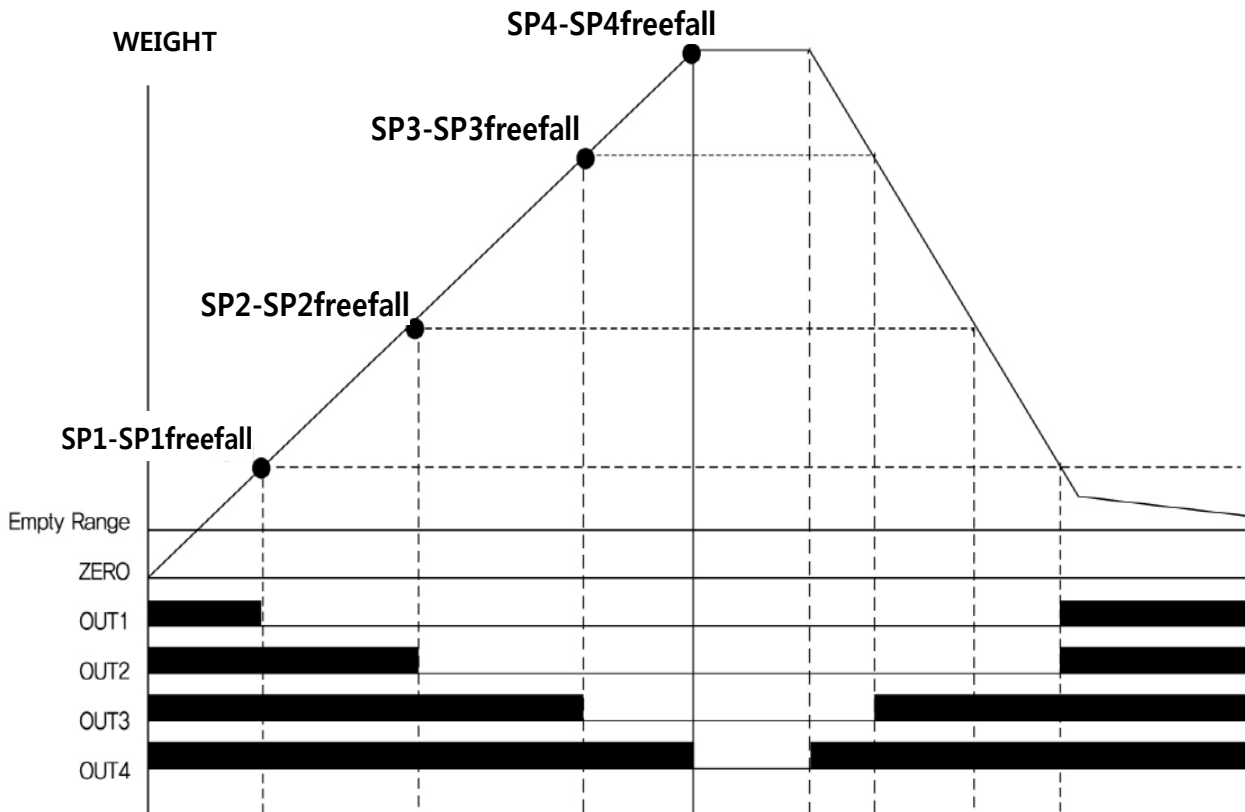

Relay Output

Relay	Contents	Relay	Contents
OUT 1	current weight \geq SP1-SP1 freefall(ON) current weight $<$ SP1-SP1 freefall(OFF)	OUT 2	current weight \geq SP2-SP2 freefall(ON) current weight $<$ SP2-SP2 freefall(OFF)
OUT 3	current weight \geq SP3-SP3 freefall(ON) current weight $<$ SP3-SP3 freefall(OFF)	OUT 4	current weight \geq SP4-SP4 freefall(ON) current weight $<$ SP4-SP4 freefall(OFF)

- The weight will be measured with absolute value, it doesn't matter +/-.
- Free fall setting mode can be set only weighing mode F21 -1, F21-2, F21-6, F21-7, F21-8.
- Free fall value $<$ Target value, If you set wrongly, "Err-B" shows.
- Default Free fall value is "0".

SI 580E DIN SIZE WEIGHING CONTROLLER

◆ Weighing Mode 7 – Accumulating Mode 1 (F21 – 07 Setting)

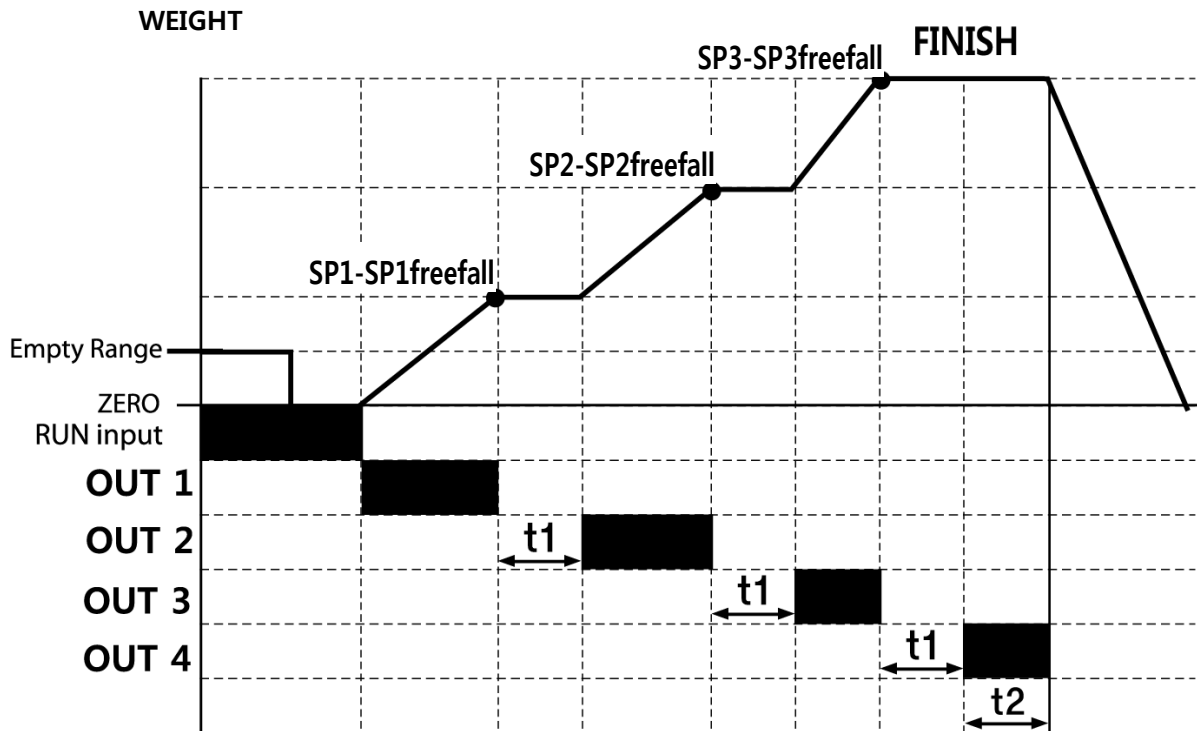

Relay Output

Relay	Output	Relay	Output
OUT 1	Current weight \geq SP1-SP1- freefall (ON)	OUT 2	Current weight \geq SP2-SP2 freefall (ON)
	Current weight $<$ SP1-SP1 freefall(OFF)		Current weight $<$ SP2-SP2 freefall (OFF)
OUT 3	Current weight \geq SP3-SP3 freefall(ON)	OUT 4	At SP3
	Current weight $<$ SP3-SP3 freefall (OFF)		after "t1" during "t2" ON

- The weight will be measured with absolute value, it doesn't matter +/-.
- Free fall setting mode can be set only weighing mode F21 -1, F21-2, F21-6, F21-7, F21-8.
- Free fall value $<$ Target value, If you set wrongly, "Err-B" shows.
- Default Free fall value is "0".

SI 580E DIN SIZE WEIGHING CONTROLLER

◆ Weighing Mode 8 – Accumulating Mode 2 (F21 – 08 Setting)

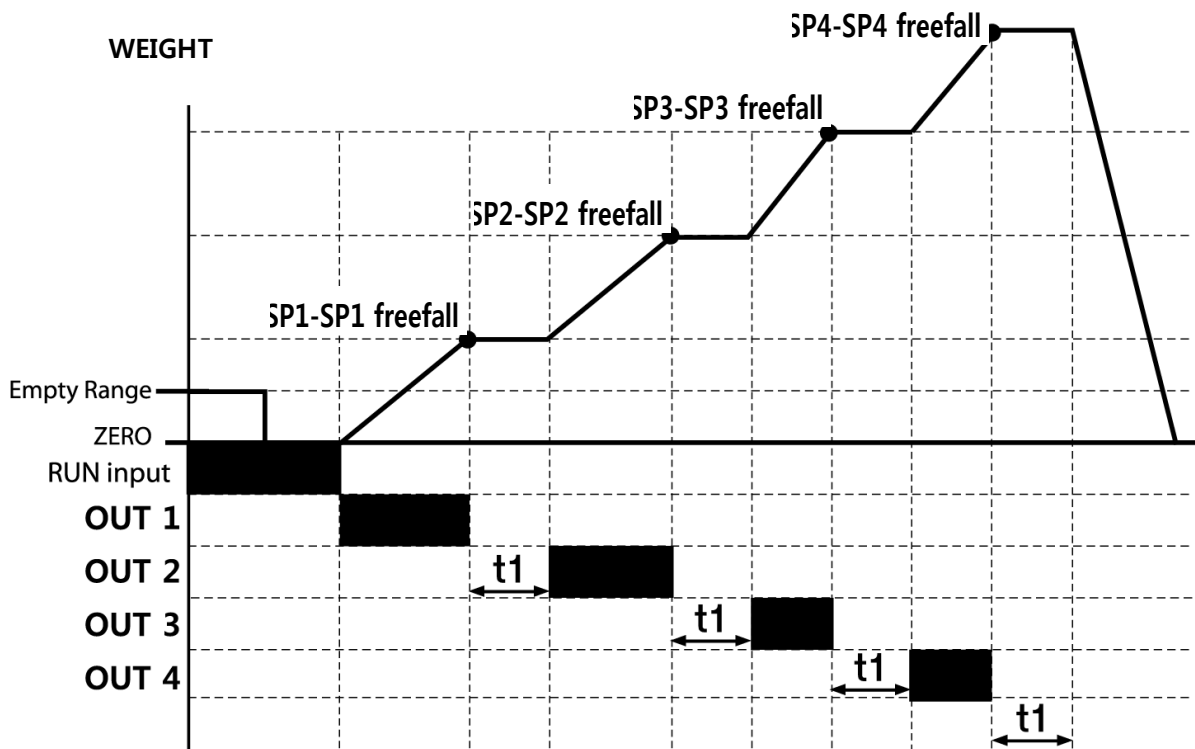

Relay Output

Relay	Output	Relay	Output
OUT 1	Empty < Current weight < SP1-SP1 freefall (ON) Current weight ≥ SP1-SP1 freefall (OFF)	OUT 2	SP1 < Current weight < SP2-SP2 freefall Current weight ≥ SP2-SP2 freefall (OFF)
OUT 3	SP2 < Current weight < SP3-SP3 freefall (ON) Current weight ≥ SP3-SP3 freefall (OFF)	OUT 4	At SP4 after "t1" during "t2" ON

- The weight will be measured with absolute value, it doesn't matter +/-.
- Free fall setting mode can be set only weighing mode F21 -1, F21-2, F21-6, F21-7, F21-8.
- Free fall value < Target value, If you set wrongly, "Err-B" shows.
- Default Free fall value is "0".

SI 580E DIN SIZE WEIGHING CONTROLLER

5-6. Test Mode



Before starting the TEST mode, please remove other connected devices.

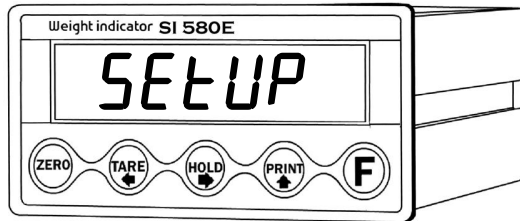



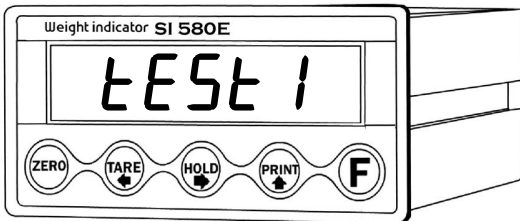



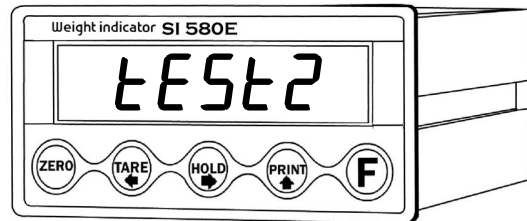



Under "SETUP" mode, press  key.



TEST MODE 1



TEST MODE 2

TEST MODE 1				
				
ESC / BACK	Analog value Check Mode	Analog Variation Value Check Mode	Key/Digital Input Check Mode	Go back to Test Mode 2
TEST MODE 2				
				
ESC / BACK	Relay Output Check Mode	4~20mA/0~10V Check Mode	Standard Serial I/F Check Mode	Extended Serial I/F Check Mode

Tip If there is no change although pressing keys or loading some force on/in weighing part , it may something wrong with load cell, cable, connector or A/D board

SI 580E DIN SIZE WEIGHING CONTROLLER

5-6-1. Analog Check Mode

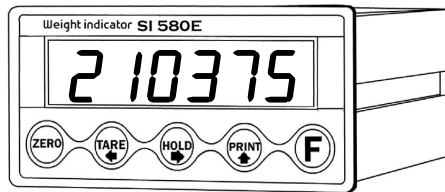

Under this mode, you can check analogue value to real digital value through Display. The last digital value can be fluctuated.

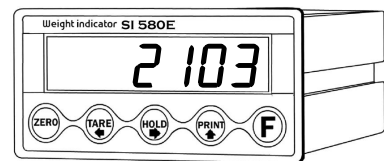
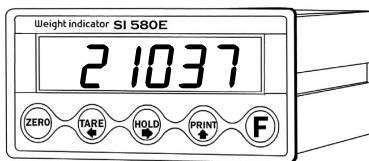
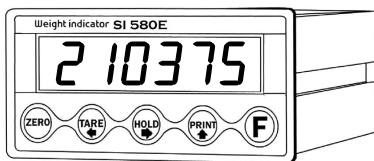

Showing 100,000~



Showing 1,000,000~



Showing 10,000,000~

5-6-2. Analogue Value Check Mode

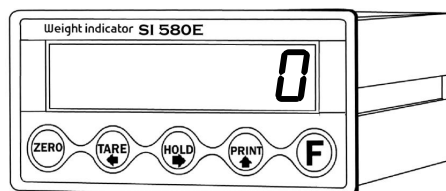

Under this mode, you can check the variation degree of analogue value.

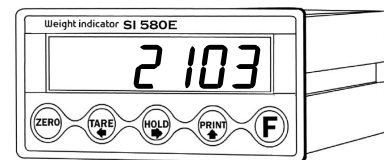
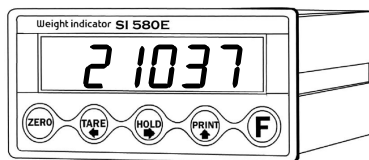
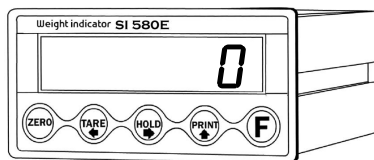

Zero Key



Showing 1,000,000~



Showing 10,000,000~

-  key means ESC/going to previous step ,  key means SAVE.

SI 580E DIN SIZE WEIGHING CONTROLLER

5-6-3. Key / Digital input Test Mode

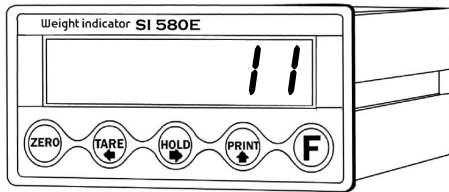

Under this mode, you can test Key input and Digital Key input test.

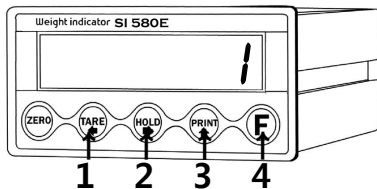

First display position is for key pad input

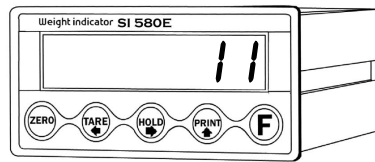

Second display position is for digital input

Whenever pressing key pad or plus to digital input terminal, the matched No. will be displayed on the each position.

5-6-4. Relay Output Test Mode

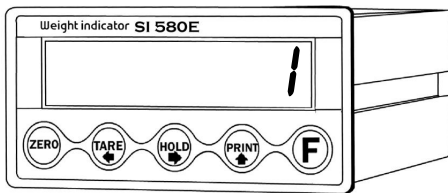

Each relay will be output by sequence.
Total 4pcs relay will be output one by one and circle continuous.
Before testing this mode, please remove all the operating devices from relay output terminal.

5-6-5. Analogue output Test Mode. (4~20mA / 0~10V)

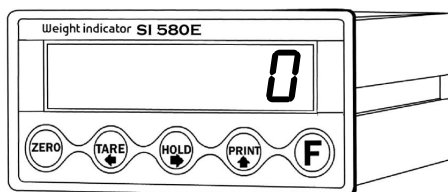

Using Simulation, you can change the weight value and check the analogue output (4~20mA / 0~10V) difference from output terminal.

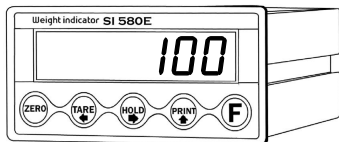

Increase



Decrease



100% output



0% output

- **ZERO** key means ESC/going to previous step , **F** key means SAVE.

SI 580E DIN SIZE WEIGHING CONTROLLER

5-6-6. Standard Serial Interface Test Mode.

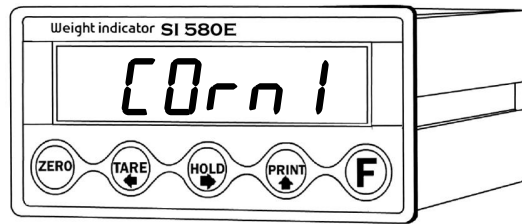

Connect with PC or other devices through serial interface and check the transference and receipt. At the normal operation, display will be blinked.

5-6-7. Extended Serial Interface Test Mode.

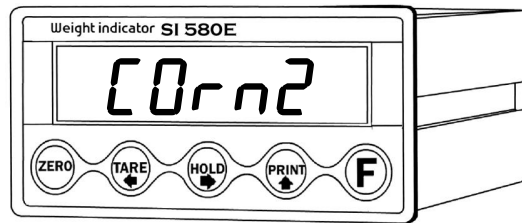

Connect with PC or other devices through serial interface and check the transference and receipt. At the normal operation, display will be blinked.

To test this mode, please use "TESTING Protocol".

※ TESTING PROTOCOL

- Format : STX Id No. TEST ETX



You cannot test Standard and Extended Serial Interface at the same time.
※If you send "Testing protocol" from PC to Indicator, at the normal operation Display will blink.

6. INTERFACE

6-1-1. Serial Interface (RS – 422)

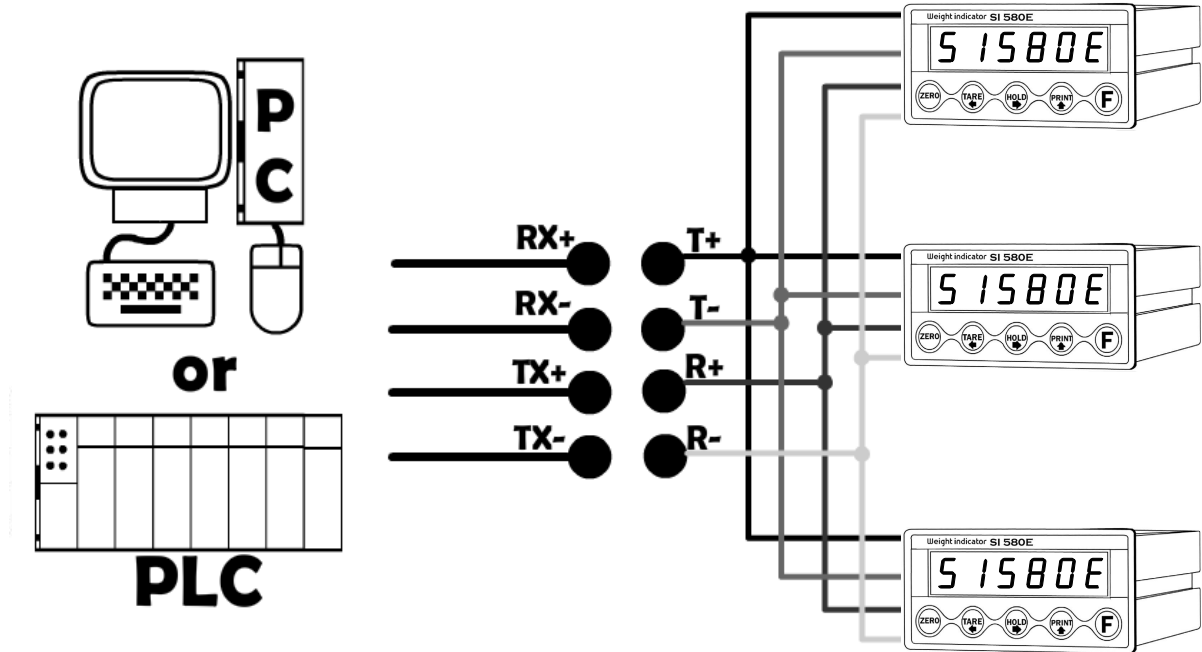

32 pcs of Indicators are connectable.

6-1-2. Serial Interface (RS – 485)

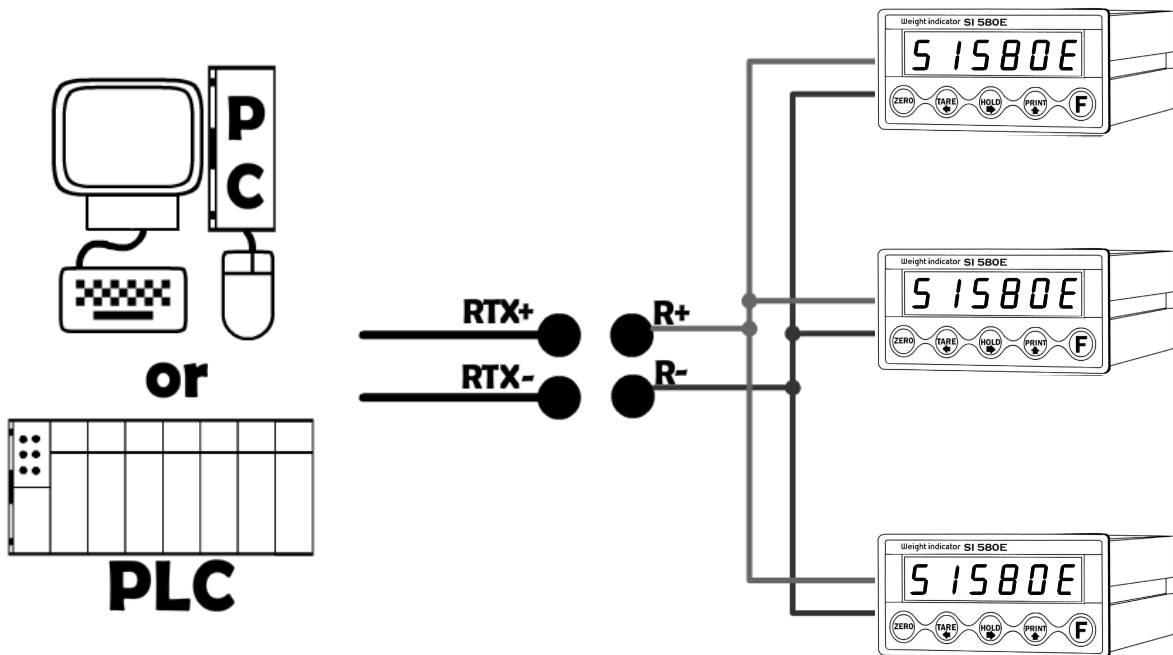

32 pcs of Indicators are connectable.

SI 580E DIN SIZE WEIGHING CONTROLLER

6-1-3. Serial Interface (RS – 232)

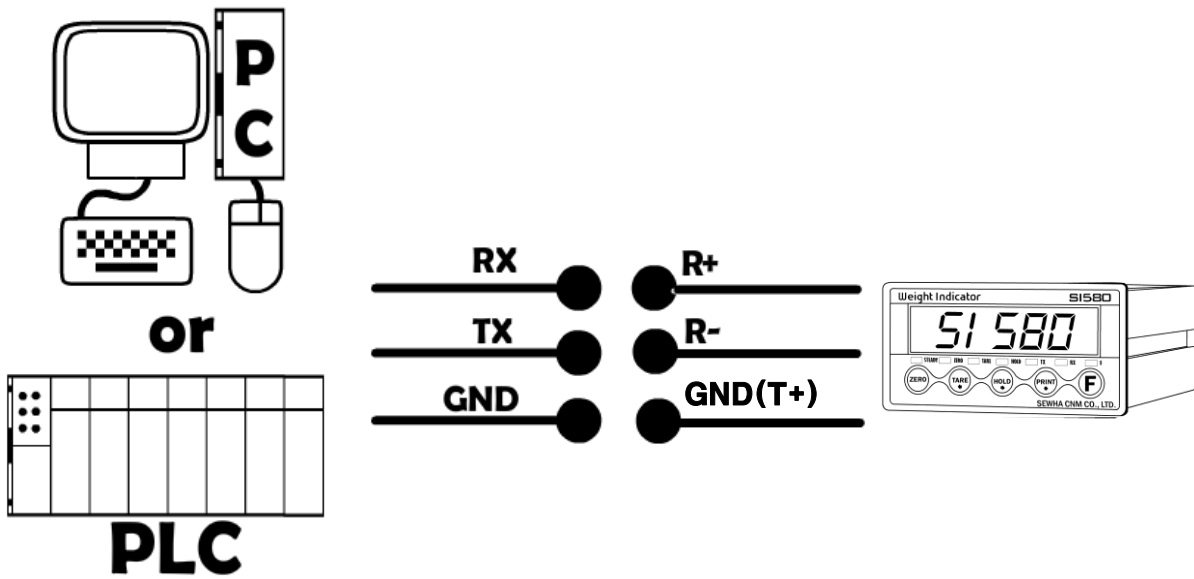

Caution

Serial communication **interface** is sensitive to electric noise.

Install isolated place from Power cable or other electric cables and wires,
and please use shielded cable for better performance.

SI 580E DIN SIZE WEIGHING CONTROLER

6-1-4. Data Format

1. Data Format1 : ID Number is not be transferred.(Refer "FUNCTION 37/67-00")

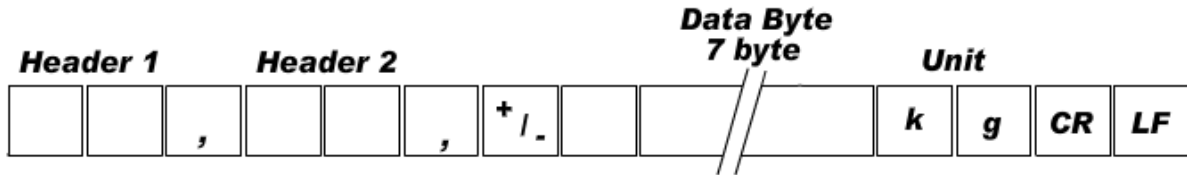

Header1	Header2
OL : OVER LOAD	NT : NET-WEIGHT(Tare is not set)
ST : Stable	GS : when setting TARE
US : Unstable	

2. Data Format2 : ID Number + Data Transference (Refer F-function 37/67-01, F18)

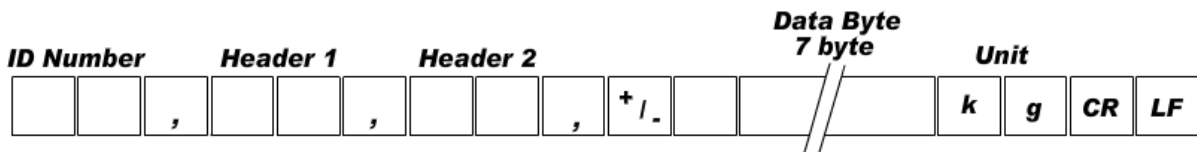

Header1	Header2
OL : OVER LOAD	NT : NET-WEIGHT(Tare is not set)
ST : Stable	GS : when setting TARE
US : Unstable	

3. Data Format3 : ID Number + State (Refer F-function 37/67-02)

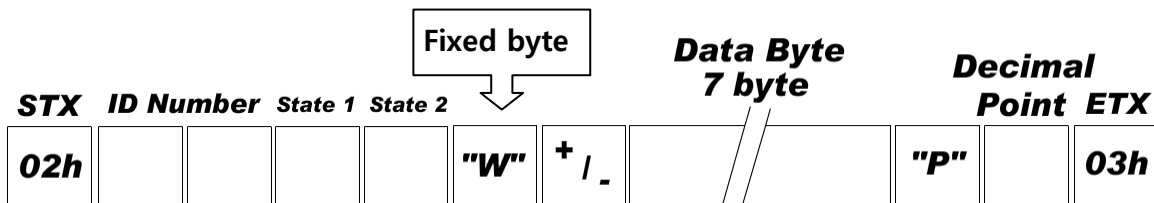

State 1	State 2	Fixed byte
O : OVER	G : Gross weight	
S : STEADY	N : Net weight	
U : UNSTABLE		

SI 580E DIN SIZE WEIGHING CONTROLER

4. CAS Format (22byte) (Refer F-function 37/67-03)

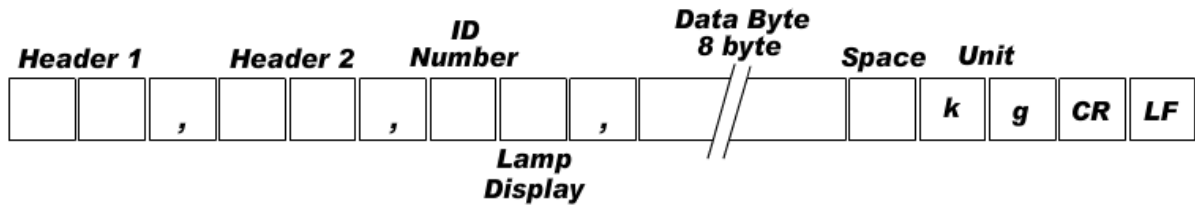

LAMP DISPLAY

Bit 7	Bit 6	Bit 5	Bit 4	Bit 3	Bit 2	Bit 1	Bit 0
1	0	1	1	1	1	1	1
1	STABLE	1	Hold	Print	Gross Weight	TARE	ZERO

Header1	Header2
OL : OVER LOAD	NT : GROSS weight
ST : Stable	GS : Net weight
US : Unstable	

6-1-5. Command Mode

Under "Command Mode", Indicator will recognize the receipt of Order based on 02h(Header) and 03h(END) signal, and transfers ACK/ NAK).

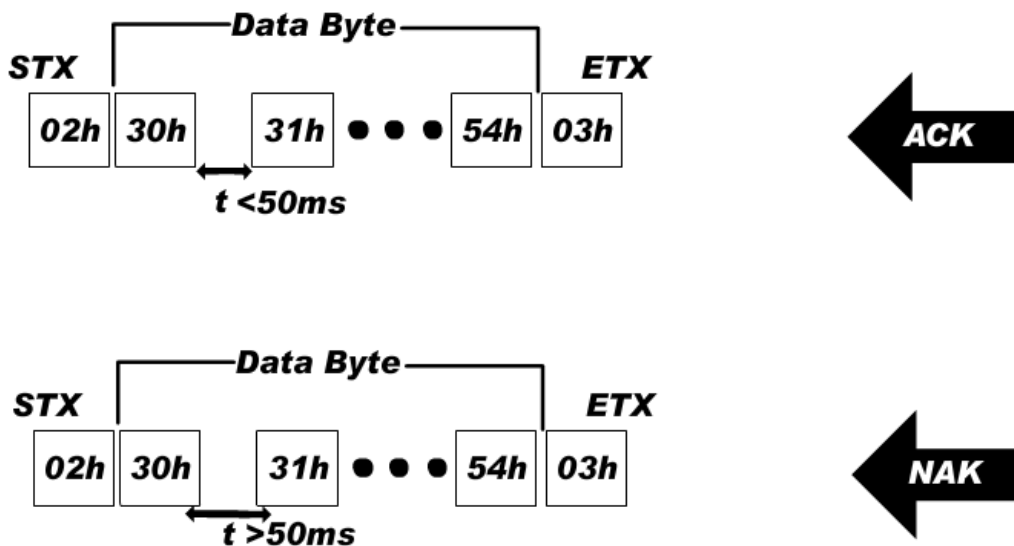

Although wrong value is transmitted, the communication format is not matched, then ACK is transmitted.

SI 580E DIN SIZE WEIGHING CONTROLER

■ Read Command

Current Weight																																																																																								
ASCII : STX ID(2Byte) RCWT ETX	HEX : 02 30 31 52 43 57 54 03																																																																																							
SI 580E response	STX ID RCWT State1(1byte) State2(1byte) P decimal point(1byte) +/- (1byte) Current weight(7byte) Weight unit(2byte) ETX																																																																																							
	State1 : O(over weight) , S(Steady), U(Unsteady) State2 : N(Net weight), G(Gross weight)																																																																																							
Ex) Steady(S), TARE not used(N), 0.000kg State1, State2, Decimal point																																																																																								
<table style="width: 100%; border-collapse: collapse; font-family: monospace;"> <tr> <td style="border: none;">STX</td><td style="border: none;">ID</td><td style="border: none;">R</td><td style="border: none;">C</td><td style="border: none;">W</td><td style="border: none;">T</td><td style="border: none; border-bottom: 1px solid red;">S</td><td style="border: none; border-bottom: 1px solid red;">N</td><td style="border: none; border-bottom: 1px solid red;">P</td><td style="border: none; border-bottom: 1px solid red;">3</td><td style="border: none;">+</td><td style="border: none;">0</td><td style="border: none;">0</td><td style="border: none;">0</td><td style="border: none;">0</td><td style="border: none;">0</td><td style="border: none;">0</td><td style="border: none;">0</td><td style="border: none;">0</td><td style="border: none;">k</td><td style="border: none;">g</td><td style="border: none;">ETX</td> </tr> <tr> <td style="border: none;">02h</td><td style="border: none;">30h</td><td style="border: none;">31h</td><td style="border: none;">52h</td><td style="border: none;">43h</td><td style="border: none;">57h</td><td style="border: none;">54h</td><td style="border: none;">53h</td><td style="border: none;">4Eh</td><td style="border: none;">50h</td><td style="border: none;">33h</td><td style="border: none;">2Bh</td><td style="border: none;">30h</td><td style="border: none;">30h</td><td style="border: none;">30h</td><td style="border: none;">30h</td><td style="border: none;">30h</td><td style="border: none;">30h</td><td style="border: none;">30h</td><td style="border: none;">6Bh</td><td style="border: none;">67h</td><td style="border: none;">03h</td> </tr> </table>		STX	ID	R	C	W	T	S	N	P	3	+	0	0	0	0	0	0	0	0	k	g	ETX	02h	30h	31h	52h	43h	57h	54h	53h	4Eh	50h	33h	2Bh	30h	30h	30h	30h	30h	30h	30h	6Bh	67h	03h																																											
STX	ID	R	C	W	T	S	N	P	3	+	0	0	0	0	0	0	0	0	k	g	ETX																																																																			
02h	30h	31h	52h	43h	57h	54h	53h	4Eh	50h	33h	2Bh	30h	30h	30h	30h	30h	30h	30h	6Bh	67h	03h																																																																			
Indicator memory data																																																																																								
ASCII : STX ID(2Byte) RCWD ETX	HEX : 02 30 31 52 43 57 44 03																																																																																							
SI 580E response	STX ID RCWD P decimal point No.(1byte)DATE(6byte) TIME(6byte) S/N(6byte) +/- TARE(7Byte) +/- (1byte) current tare weight(7byte) +/- (1byte) current weight(7byte) weight unit(2byte) ETX																																																																																							
	Ex) DATE : Aug 12 th ,2009 TIME : 12:00:00 P/N : 10 TARE : 2.000kg current weight : 3.000kg decimal point																																																																																							
<table style="width: 100%; border-collapse: collapse; font-family: monospace;"> <tr> <td style="border: none;">STX</td><td style="border: none;">ID</td><td style="border: none;">R</td><td style="border: none;">C</td><td style="border: none;">W</td><td style="border: none;">D</td><td style="border: none; border-bottom: 1px solid red;">P</td><td style="border: none; border-bottom: 1px solid red;">3</td><td style="border: none;">0</td><td style="border: none;">9</td><td style="border: none;">0</td><td style="border: none;">8</td><td style="border: none;">1</td><td style="border: none;">2</td><td style="border: none;">1</td><td style="border: none;">2</td><td style="border: none;">0</td><td style="border: none;">0</td><td style="border: none;">0</td><td style="border: none;">0</td> </tr> <tr> <td style="border: none;">02h</td><td style="border: none;">30h</td><td style="border: none;">31h</td><td style="border: none;">52h</td><td style="border: none;">43h</td><td style="border: none;">57h</td><td style="border: none;">44h</td><td style="border: none;">50h</td><td style="border: none;">33h</td><td style="border: none;">30h</td><td style="border: none;">39h</td><td style="border: none;">30h</td><td style="border: none;">38h</td><td style="border: none;">31h</td><td style="border: none;">32h</td><td style="border: none;">31h</td><td style="border: none;">31h</td><td style="border: none;">30h</td><td style="border: none;">30h</td><td style="border: none;">30h</td><td style="border: none;">30h</td> </tr> <tr> <td style="border: none;">0</td><td style="border: none;">0</td><td style="border: none;">0</td><td style="border: none;">0</td><td style="border: none;">1</td><td style="border: none;">0</td><td style="border: none;">+</td><td style="border: none;">0</td><td style="border: none;">0</td><td style="border: none;">0</td><td style="border: none;">2</td><td style="border: none;">0</td><td style="border: none;">0</td><td style="border: none;">0</td><td style="border: none;">+</td><td style="border: none;">0</td><td style="border: none;">0</td><td style="border: none;">0</td><td style="border: none;">3</td><td style="border: none;">0</td><td style="border: none;">0</td><td style="border: none;">0</td><td style="border: none;">ETX</td> </tr> <tr> <td style="border: none;">30h</td><td style="border: none;">30h</td><td style="border: none;">30h</td><td style="border: none;">30h</td><td style="border: none;">31h</td><td style="border: none;">30h</td><td style="border: none;">2Bh</td><td style="border: none;">30h</td><td style="border: none;">30h</td><td style="border: none;">30h</td><td style="border: none;">32h</td><td style="border: none;">30h</td><td style="border: none;">30h</td><td style="border: none;">30h</td><td style="border: none;">2Bh</td><td style="border: none;">32h</td><td style="border: none;">30h</td><td style="border: none;">30h</td><td style="border: none;">33h</td><td style="border: none;">30h</td><td style="border: none;">30h</td><td style="border: none;">30h</td><td style="border: none;">03h</td> </tr> </table>		STX	ID	R	C	W	D	P	3	0	9	0	8	1	2	1	2	0	0	0	0	02h	30h	31h	52h	43h	57h	44h	50h	33h	30h	39h	30h	38h	31h	32h	31h	31h	30h	30h	30h	30h	0	0	0	0	1	0	+	0	0	0	2	0	0	0	+	0	0	0	3	0	0	0	ETX	30h	30h	30h	30h	31h	30h	2Bh	30h	30h	30h	32h	30h	30h	30h	2Bh	32h	30h	30h	33h	30h	30h	30h	03h
STX	ID	R	C	W	D	P	3	0	9	0	8	1	2	1	2	0	0	0	0																																																																					
02h	30h	31h	52h	43h	57h	44h	50h	33h	30h	39h	30h	38h	31h	32h	31h	31h	30h	30h	30h	30h																																																																				
0	0	0	0	1	0	+	0	0	0	2	0	0	0	+	0	0	0	3	0	0	0	ETX																																																																		
30h	30h	30h	30h	31h	30h	2Bh	30h	30h	30h	32h	30h	30h	30h	2Bh	32h	30h	30h	33h	30h	30h	30h	03h																																																																		
Grand Total Data																																																																																								
ASCII : STX ID(2Byte) RGRD ETX	HEX : 02 30 31 52 43 57 44 03																																																																																							
SI 580E response	STX ID RGRD P decimal point(1byte)Accumulated S/N count (6byte) Accumulated weight(10byte) weight unit(2byte) ETX																																																																																							
	Ex) S/N : 10 , Accumulated Weight : 10.000kg decimal point																																																																																							
<table style="width: 100%; border-collapse: collapse; font-family: monospace;"> <tr> <td style="border: none;">STX</td><td style="border: none;">ID</td><td style="border: none;">R</td><td style="border: none;">G</td><td style="border: none;">R</td><td style="border: none;">D</td><td style="border: none; border-bottom: 1px solid red;">P</td><td style="border: none; border-bottom: 1px solid red;">3</td><td style="border: none;">0</td><td style="border: none;">0</td><td style="border: none;">0</td><td style="border: none;">0</td><td style="border: none;">1</td><td style="border: none;">0</td><td style="border: none;">0</td><td style="border: none;">0</td><td style="border: none;">0</td><td style="border: none;">1</td><td style="border: none;">0</td><td style="border: none;">0</td><td style="border: none;">0</td><td style="border: none;">0</td><td style="border: none;">ETX</td> </tr> <tr> <td style="border: none;">02h</td><td style="border: none;">30h</td><td style="border: none;">31h</td><td style="border: none;">52h</td><td style="border: none;">47h</td><td style="border: none;">52h</td><td style="border: none;">44h</td><td style="border: none;">50h</td><td style="border: none;">33h</td><td style="border: none;">30h</td><td style="border: none;">30h</td><td style="border: none;">30h</td><td style="border: none;">30h</td><td style="border: none;">31h</td><td style="border: none;">30h</td><td style="border: none;">30h</td><td style="border: none;">30h</td><td style="border: none;">30h</td><td style="border: none;">31h</td><td style="border: none;">30h</td><td style="border: none;">30h</td><td style="border: none;">30h</td><td style="border: none;">03h</td> </tr> </table>		STX	ID	R	G	R	D	P	3	0	0	0	0	1	0	0	0	0	1	0	0	0	0	ETX	02h	30h	31h	52h	47h	52h	44h	50h	33h	30h	30h	30h	30h	31h	30h	30h	30h	30h	31h	30h	30h	30h	03h																																									
STX	ID	R	G	R	D	P	3	0	0	0	0	1	0	0	0	0	1	0	0	0	0	ETX																																																																		
02h	30h	31h	52h	47h	52h	44h	50h	33h	30h	30h	30h	30h	31h	30h	30h	30h	30h	31h	30h	30h	30h	03h																																																																		
Finished Weight Data																																																																																								
ASCII : STX ID(2Byte) RFIN ETX	HEX: 02 30 31 52 46 49 4E 03																																																																																							
SI 580E response	STX ID RFIN P decimal point(1byte) +/- (1byte) Finished weight(7byte) ETX																																																																																							
	Ex) Finished weight : 2.000kg decimal point																																																																																							
<table style="width: 100%; border-collapse: collapse; font-family: monospace;"> <tr> <td style="border: none;">STX</td><td style="border: none;">ID</td><td style="border: none;">R</td><td style="border: none;">F</td><td style="border: none;">I</td><td style="border: none;">N</td><td style="border: none; border-bottom: 1px solid red;">P</td><td style="border: none; border-bottom: 1px solid red;">3</td><td style="border: none;">+</td><td style="border: none;">0</td><td style="border: none;">0</td><td style="border: none;">0</td><td style="border: none;">2</td><td style="border: none;">0</td><td style="border: none;">0</td><td style="border: none;">0</td><td style="border: none;">ETX</td> </tr> <tr> <td style="border: none;">02h</td><td style="border: none;">30h</td><td style="border: none;">31h</td><td style="border: none;">52h</td><td style="border: none;">46h</td><td style="border: none;">49h</td><td style="border: none;">4Eh</td><td style="border: none;">50h</td><td style="border: none;">33h</td><td style="border: none;">2Bh</td><td style="border: none;">30h</td><td style="border: none;">30h</td><td style="border: none;">30h</td><td style="border: none;">32h</td><td style="border: none;">30h</td><td style="border: none;">30h</td><td style="border: none;">30h</td><td style="border: none;">03h</td> </tr> </table>		STX	ID	R	F	I	N	P	3	+	0	0	0	2	0	0	0	ETX	02h	30h	31h	52h	46h	49h	4Eh	50h	33h	2Bh	30h	30h	30h	32h	30h	30h	30h	03h																																																				
STX	ID	R	F	I	N	P	3	+	0	0	0	2	0	0	0	ETX																																																																								
02h	30h	31h	52h	46h	49h	4Eh	50h	33h	2Bh	30h	30h	30h	32h	30h	30h	30h	03h																																																																							

SI 580E DIN SIZE WEIGHING CONTROLER

Current Time Data																																				
ASCII : STX ID(2Byte) RTIM ETX	HEX: 02 30 31 52 54 49 4D 03																																			
SI 580E response	STX ID RTIM Current Time(6byte) ETX																																			
Ex) Time : 12:00:00																																				
<table border="0" style="margin: auto;"> <tr> <td>STX</td> <td>ID</td> <td>R</td> <td>T</td> <td>I</td> <td>M</td> <td>1</td> <td>2</td> <td>0</td> <td>0</td> <td>0</td> <td>0</td> <td>0</td> <td>0</td> <td>ETX</td> </tr> <tr> <td style="border: 1px solid black; text-align: center;">02h</td> <td style="border: 1px solid black; text-align: center;">30h</td> <td style="border: 1px solid black; text-align: center;">31h</td> <td style="border: 1px solid black; text-align: center;">52h</td> <td style="border: 1px solid black; text-align: center;">54h</td> <td style="border: 1px solid black; text-align: center;">49h</td> <td style="border: 1px solid black; text-align: center;">4Dh</td> <td style="border: 1px solid black; text-align: center;">31h</td> <td style="border: 1px solid black; text-align: center;">32h</td> <td style="border: 1px solid black; text-align: center;">30h</td> <td style="border: 1px solid black; text-align: center;">30h</td> <td style="border: 1px solid black; text-align: center;">30h</td> <td style="border: 1px solid black; text-align: center;">30h</td> <td style="border: 1px solid black; text-align: center;">03h</td> </tr> </table>		STX	ID	R	T	I	M	1	2	0	0	0	0	0	0	ETX	02h	30h	31h	52h	54h	49h	4Dh	31h	32h	30h	30h	30h	30h	03h						
STX	ID	R	T	I	M	1	2	0	0	0	0	0	0	ETX																						
02h	30h	31h	52h	54h	49h	4Dh	31h	32h	30h	30h	30h	30h	03h																							
Current Date Data																																				
ASCII : STX ID(2Byte) R DAT ETX	HEX : 02 30 31 52 44 41 54 03																																			
SI 580E response	STX ID R DAT Current Date(6byte) ETX																																			
Ex) Date : Aug 12 th ,2009																																				
<table border="0" style="margin: auto;"> <tr> <td>STX</td> <td>ID</td> <td>R</td> <td>D</td> <td>A</td> <td>T</td> <td>0</td> <td>9</td> <td>0</td> <td>8</td> <td>1</td> <td>2</td> <td>ETX</td> </tr> <tr> <td style="border: 1px solid black; text-align: center;">02h</td> <td style="border: 1px solid black; text-align: center;">30h</td> <td style="border: 1px solid black; text-align: center;">31h</td> <td style="border: 1px solid black; text-align: center;">52h</td> <td style="border: 1px solid black; text-align: center;">41h</td> <td style="border: 1px solid black; text-align: center;">41h</td> <td style="border: 1px solid black; text-align: center;">54h</td> <td style="border: 1px solid black; text-align: center;">30h</td> <td style="border: 1px solid black; text-align: center;">39h</td> <td style="border: 1px solid black; text-align: center;">30h</td> <td style="border: 1px solid black; text-align: center;">38h</td> <td style="border: 1px solid black; text-align: center;">31h</td> <td style="border: 1px solid black; text-align: center;">32h</td> <td style="border: 1px solid black; text-align: center;">03h</td> </tr> </table>		STX	ID	R	D	A	T	0	9	0	8	1	2	ETX	02h	30h	31h	52h	41h	41h	54h	30h	39h	30h	38h	31h	32h	03h								
STX	ID	R	D	A	T	0	9	0	8	1	2	ETX																								
02h	30h	31h	52h	41h	41h	54h	30h	39h	30h	38h	31h	32h	03h																							
Tare Data																																				
ASCII : STX ID(2Byte) RTAR ETX	HEX : 02 30 31 52 54 41 52 03																																			
SI 580E response	STX ID RTAR P decimal point(1byte) +/- (1byte) TARE vlaue(7byte) ETX																																			
Ex) TARE : 2.000kg <u>decimal point</u>																																				
<table border="0" style="margin: auto;"> <tr> <td>STX</td> <td>ID</td> <td>R</td> <td>T</td> <td>A</td> <td>R</td> <td>P</td> <td>3</td> <td>+</td> <td>0</td> <td>0</td> <td>0</td> <td>2</td> <td>0</td> <td>0</td> <td>0</td> <td>ETX</td> </tr> <tr> <td style="border: 1px solid black; text-align: center;">02h</td> <td style="border: 1px solid black; text-align: center;">30h</td> <td style="border: 1px solid black; text-align: center;">31h</td> <td style="border: 1px solid black; text-align: center;">52h</td> <td style="border: 1px solid black; text-align: center;">54h</td> <td style="border: 1px solid black; text-align: center;">41h</td> <td style="border: 1px solid black; text-align: center;">52h</td> <td style="border: 1px solid black; text-align: center;">50h</td> <td style="border: 1px solid black; text-align: center;">33h</td> <td style="border: 1px solid black; text-align: center;">2Bh</td> <td style="border: 1px solid black; text-align: center;">30h</td> <td style="border: 1px solid black; text-align: center;">30h</td> <td style="border: 1px solid black; text-align: center;">30h</td> <td style="border: 1px solid black; text-align: center;">32h</td> <td style="border: 1px solid black; text-align: center;">30h</td> <td style="border: 1px solid black; text-align: center;">30h</td> <td style="border: 1px solid black; text-align: center;">30h</td> <td style="border: 1px solid black; text-align: center;">03h</td> </tr> </table>		STX	ID	R	T	A	R	P	3	+	0	0	0	2	0	0	0	ETX	02h	30h	31h	52h	54h	41h	52h	50h	33h	2Bh	30h	30h	30h	32h	30h	30h	30h	03h
STX	ID	R	T	A	R	P	3	+	0	0	0	2	0	0	0	ETX																				
02h	30h	31h	52h	54h	41h	52h	50h	33h	2Bh	30h	30h	30h	32h	30h	30h	30h	03h																			
Set Point1 Set value																																				
ASCII : STX ID(2Byte) RSP1 ETX	HEX : 02 30 31 52 53 50 31 03																																			
SI 580E response	STX ID P decimal point(1byte) set value(7byte) ETX																																			
Ex) SP1 : 5.000 <u>decimal point</u>																																				
<table border="0" style="margin: auto;"> <tr> <td>STX</td> <td>ID</td> <td>R</td> <td>S</td> <td>P</td> <td>1</td> <td>P</td> <td>3</td> <td>0</td> <td>0</td> <td>0</td> <td>5</td> <td>0</td> <td>0</td> <td>0</td> <td>ETX</td> </tr> <tr> <td style="border: 1px solid black; text-align: center;">02h</td> <td style="border: 1px solid black; text-align: center;">30h</td> <td style="border: 1px solid black; text-align: center;">31h</td> <td style="border: 1px solid black; text-align: center;">52h</td> <td style="border: 1px solid black; text-align: center;">53h</td> <td style="border: 1px solid black; text-align: center;">50h</td> <td style="border: 1px solid black; text-align: center;">31h</td> <td style="border: 1px solid black; text-align: center;">50h</td> <td style="border: 1px solid black; text-align: center;">33h</td> <td style="border: 1px solid black; text-align: center;">30h</td> <td style="border: 1px solid black; text-align: center;">30h</td> <td style="border: 1px solid black; text-align: center;">30h</td> <td style="border: 1px solid black; text-align: center;">35h</td> <td style="border: 1px solid black; text-align: center;">30h</td> <td style="border: 1px solid black; text-align: center;">30h</td> <td style="border: 1px solid black; text-align: center;">30h</td> <td style="border: 1px solid black; text-align: center;">03h</td> </tr> </table>		STX	ID	R	S	P	1	P	3	0	0	0	5	0	0	0	ETX	02h	30h	31h	52h	53h	50h	31h	50h	33h	30h	30h	30h	35h	30h	30h	30h	03h		
STX	ID	R	S	P	1	P	3	0	0	0	5	0	0	0	ETX																					
02h	30h	31h	52h	53h	50h	31h	50h	33h	30h	30h	30h	35h	30h	30h	30h	03h																				
Set Point2 set value																																				
ASCII : STX ID(2Byte) RSP2 ETX	HEX : 02 30 31 52 53 50 32 03																																			
SI 580E response	STX ID RSP2 P decimal point(1byte) set value(7byte) ETX																																			
Ex) SP2 set value : 6.000 <u>decimal point</u>																																				
<table border="0" style="margin: auto;"> <tr> <td>STX</td> <td>ID</td> <td>R</td> <td>S</td> <td>P</td> <td>2</td> <td>P</td> <td>3</td> <td>0</td> <td>0</td> <td>0</td> <td>6</td> <td>0</td> <td>0</td> <td>0</td> <td>ETX</td> </tr> <tr> <td style="border: 1px solid black; text-align: center;">02h</td> <td style="border: 1px solid black; text-align: center;">30h</td> <td style="border: 1px solid black; text-align: center;">31h</td> <td style="border: 1px solid black; text-align: center;">52h</td> <td style="border: 1px solid black; text-align: center;">53h</td> <td style="border: 1px solid black; text-align: center;">50h</td> <td style="border: 1px solid black; text-align: center;">32h</td> <td style="border: 1px solid black; text-align: center;">50h</td> <td style="border: 1px solid black; text-align: center;">33h</td> <td style="border: 1px solid black; text-align: center;">30h</td> <td style="border: 1px solid black; text-align: center;">30h</td> <td style="border: 1px solid black; text-align: center;">30h</td> <td style="border: 1px solid black; text-align: center;">36h</td> <td style="border: 1px solid black; text-align: center;">30h</td> <td style="border: 1px solid black; text-align: center;">30h</td> <td style="border: 1px solid black; text-align: center;">30h</td> <td style="border: 1px solid black; text-align: center;">03h</td> </tr> </table>		STX	ID	R	S	P	2	P	3	0	0	0	6	0	0	0	ETX	02h	30h	31h	52h	53h	50h	32h	50h	33h	30h	30h	30h	36h	30h	30h	30h	03h		
STX	ID	R	S	P	2	P	3	0	0	0	6	0	0	0	ETX																					
02h	30h	31h	52h	53h	50h	32h	50h	33h	30h	30h	30h	36h	30h	30h	30h	03h																				

SI 580E DIN SIZE WEIGHING CONTROLER

Set Point3 set value																																																																																					
ASCII : STX ID(2Byte) RSP3 ETX	HEX : 02 30 31 52 53 50 33 03																																																																																				
SI 580E response	STX ID RSP3 P decimal point(1byte) set value(7byte) ETX																																																																																				
Ex) SP3 set value : 7.000 decimal point																																																																																					
<table style="margin: auto; border-collapse: collapse;"> <tr> <td style="padding: 0 5px;">STX</td> <td style="padding: 0 5px;">ID</td> <td style="padding: 0 5px;">R</td> <td style="padding: 0 5px;">S</td> <td style="padding: 0 5px;">P</td> <td style="padding: 0 5px;">3</td> <td style="padding: 0 5px;">P</td> <td style="padding: 0 5px;">3</td> <td style="padding: 0 5px;">0</td> <td style="padding: 0 5px;">0</td> <td style="padding: 0 5px;">0</td> <td style="padding: 0 5px;">7</td> <td style="padding: 0 5px;">0</td> <td style="padding: 0 5px;">0</td> <td style="padding: 0 5px;">0</td> <td style="padding: 0 5px;">ETX</td> </tr> <tr> <td style="border: 1px solid black; text-align: center;">02h</td> <td style="border: 1px solid black; text-align: center;">30h</td> <td style="border: 1px solid black; text-align: center;">31h</td> <td style="border: 1px solid black; text-align: center;">52h</td> <td style="border: 1px solid black; text-align: center;">53h</td> <td style="border: 1px solid black; text-align: center;">50h</td> <td style="border: 1px solid black; text-align: center;">33h</td> <td style="border: 1px solid black; text-align: center;">50h</td> <td style="border: 1px solid black; text-align: center;">33h</td> <td style="border: 1px solid black; text-align: center;">30h</td> <td style="border: 1px solid black; text-align: center;">30h</td> <td style="border: 1px solid black; text-align: center;">30h</td> <td style="border: 1px solid black; text-align: center;">37h</td> <td style="border: 1px solid black; text-align: center;">30h</td> <td style="border: 1px solid black; text-align: center;">30h</td> <td style="border: 1px solid black; text-align: center;">30h</td> <td style="border: 1px solid black; text-align: center;">03h</td> </tr> </table>		STX	ID	R	S	P	3	P	3	0	0	0	7	0	0	0	ETX	02h	30h	31h	52h	53h	50h	33h	50h	33h	30h	30h	30h	37h	30h	30h	30h	03h																																																			
STX	ID	R	S	P	3	P	3	0	0	0	7	0	0	0	ETX																																																																						
02h	30h	31h	52h	53h	50h	33h	50h	33h	30h	30h	30h	37h	30h	30h	30h	03h																																																																					
Set Point4 set value																																																																																					
ASCII : STX ID(2Byte) RSP4 ETX	HEX : 02 30 31 52 53 50 34 03																																																																																				
SI 580E response	STX ID RSP4 P decimal point(1byte) set value(7byte) ETX																																																																																				
Ex) SP4 set value : 8.000 decimal point																																																																																					
<table style="margin: auto; border-collapse: collapse;"> <tr> <td style="padding: 0 5px;">STX</td> <td style="padding: 0 5px;">ID</td> <td style="padding: 0 5px;">R</td> <td style="padding: 0 5px;">S</td> <td style="padding: 0 5px;">P</td> <td style="padding: 0 5px;">4</td> <td style="padding: 0 5px;">P</td> <td style="padding: 0 5px;">3</td> <td style="padding: 0 5px;">0</td> <td style="padding: 0 5px;">0</td> <td style="padding: 0 5px;">0</td> <td style="padding: 0 5px;">8</td> <td style="padding: 0 5px;">0</td> <td style="padding: 0 5px;">0</td> <td style="padding: 0 5px;">0</td> <td style="padding: 0 5px;">ETX</td> </tr> <tr> <td style="border: 1px solid black; text-align: center;">02h</td> <td style="border: 1px solid black; text-align: center;">30h</td> <td style="border: 1px solid black; text-align: center;">31h</td> <td style="border: 1px solid black; text-align: center;">52h</td> <td style="border: 1px solid black; text-align: center;">53h</td> <td style="border: 1px solid black; text-align: center;">50h</td> <td style="border: 1px solid black; text-align: center;">34h</td> <td style="border: 1px solid black; text-align: center;">50h</td> <td style="border: 1px solid black; text-align: center;">33h</td> <td style="border: 1px solid black; text-align: center;">30h</td> <td style="border: 1px solid black; text-align: center;">30h</td> <td style="border: 1px solid black; text-align: center;">30h</td> <td style="border: 1px solid black; text-align: center;">38h</td> <td style="border: 1px solid black; text-align: center;">30h</td> <td style="border: 1px solid black; text-align: center;">30h</td> <td style="border: 1px solid black; text-align: center;">30h</td> <td style="border: 1px solid black; text-align: center;">03h</td> </tr> </table>		STX	ID	R	S	P	4	P	3	0	0	0	8	0	0	0	ETX	02h	30h	31h	52h	53h	50h	34h	50h	33h	30h	30h	30h	38h	30h	30h	30h	03h																																																			
STX	ID	R	S	P	4	P	3	0	0	0	8	0	0	0	ETX																																																																						
02h	30h	31h	52h	53h	50h	34h	50h	33h	30h	30h	30h	38h	30h	30h	30h	03h																																																																					
SP 1,2,3,4 set value																																																																																					
ASCII : STX ID(2Byte) RSPA ETX	HEX : 02 30 31 52 53 50 41 03																																																																																				
SI 580E response	STX ID RSP4 P decimal point(1byte) SP1 set value(7byte) SP2 Set value(7byte) SP3Set value(7byte) SP4Set value(7byte) ETX																																																																																				
Ex) SP1 set value : 5.000, SP2 set value : 6.000, SP3 set value : 7.000, SP4 set value : 8.000																																																																																					
<table style="margin: auto; border-collapse: collapse;"> <tr> <td style="padding: 0 5px;">STX</td> <td style="padding: 0 5px;">ID</td> <td style="padding: 0 5px;">R</td> <td style="padding: 0 5px;">S</td> <td style="padding: 0 5px;">P</td> <td style="padding: 0 5px;">A</td> <td style="padding: 0 5px;">P</td> <td style="padding: 0 5px;">3</td> <td style="padding: 0 5px;">0</td> <td style="padding: 0 5px;">0</td> <td style="padding: 0 5px;">0</td> <td style="padding: 0 5px;">5</td> <td style="padding: 0 5px;">0</td> <td style="padding: 0 5px;">0</td> <td style="padding: 0 5px;">0</td> <td style="padding: 0 5px;">0</td> <td style="padding: 0 5px;">0</td> </tr> <tr> <td style="border: 1px solid black; text-align: center;">02h</td> <td style="border: 1px solid black; text-align: center;">30h</td> <td style="border: 1px solid black; text-align: center;">31h</td> <td style="border: 1px solid black; text-align: center;">52h</td> <td style="border: 1px solid black; text-align: center;">53h</td> <td style="border: 1px solid black; text-align: center;">50h</td> <td style="border: 1px solid black; text-align: center;">41h</td> <td style="border: 1px solid black; text-align: center;">50h</td> <td style="border: 1px solid black; text-align: center;">33h</td> <td style="border: 1px solid black; text-align: center;">30h</td> <td style="border: 1px solid black; text-align: center;">30h</td> <td style="border: 1px solid black; text-align: center;">35h</td> <td style="border: 1px solid black; text-align: center;">30h</td> <td style="border: 1px solid black; text-align: center;">30h</td> <td style="border: 1px solid black; text-align: center;">30h</td> <td style="border: 1px solid black; text-align: center;">30h</td> <td style="border: 1px solid black; text-align: center;">30h</td> </tr> <tr> <td style="padding: 0 5px;">6</td> <td style="padding: 0 5px;">0</td> <td style="padding: 0 5px;">0</td> <td style="padding: 0 5px;">0</td> <td style="padding: 0 5px;">0</td> <td style="padding: 0 5px;">0</td> <td style="padding: 0 5px;">0</td> <td style="padding: 0 5px;">7</td> <td style="padding: 0 5px;">0</td> <td style="padding: 0 5px;">0</td> <td style="padding: 0 5px;">0</td> <td style="padding: 0 5px;">0</td> <td style="padding: 0 5px;">0</td> <td style="padding: 0 5px;">0</td> <td style="padding: 0 5px;">0</td> <td style="padding: 0 5px;">8</td> <td style="padding: 0 5px;">0</td> </tr> <tr> <td style="border: 1px solid black; text-align: center;">36h</td> <td style="border: 1px solid black; text-align: center;">30h</td> <td style="border: 1px solid black; text-align: center;">30h</td> <td style="border: 1px solid black; text-align: center;">30h</td> <td style="border: 1px solid black; text-align: center;">30h</td> <td style="border: 1px solid black; text-align: center;">30h</td> <td style="border: 1px solid black; text-align: center;">30h</td> <td style="border: 1px solid black; text-align: center;">37h</td> <td style="border: 1px solid black; text-align: center;">30h</td> <td style="border: 1px solid black; text-align: center;">30h</td> <td style="border: 1px solid black; text-align: center;">30h</td> <td style="border: 1px solid black; text-align: center;">30h</td> <td style="border: 1px solid black; text-align: center;">30h</td> <td style="border: 1px solid black; text-align: center;">30h</td> <td style="border: 1px solid black; text-align: center;">38h</td> <td style="border: 1px solid black; text-align: center;">30h</td> <td style="border: 1px solid black; text-align: center;">30h</td> </tr> <tr> <td style="padding: 0 5px;">ETX</td> <td colspan="15"></td> </tr> </table>		STX	ID	R	S	P	A	P	3	0	0	0	5	0	0	0	0	0	02h	30h	31h	52h	53h	50h	41h	50h	33h	30h	30h	35h	30h	30h	30h	30h	30h	6	0	0	0	0	0	0	7	0	0	0	0	0	0	0	8	0	36h	30h	30h	30h	30h	30h	30h	37h	30h	30h	30h	30h	30h	30h	38h	30h	30h	ETX															
STX	ID	R	S	P	A	P	3	0	0	0	5	0	0	0	0	0																																																																					
02h	30h	31h	52h	53h	50h	41h	50h	33h	30h	30h	35h	30h	30h	30h	30h	30h																																																																					
6	0	0	0	0	0	0	7	0	0	0	0	0	0	0	8	0																																																																					
36h	30h	30h	30h	30h	30h	30h	37h	30h	30h	30h	30h	30h	30h	38h	30h	30h																																																																					
ETX																																																																																					
Current weight, Input, Output situation																																																																																					
ASCII : STX ID(2Byte) RWRS ETX	HEX : 02 30 31 52 57 52 53 03																																																																																				
SI 580E response	STX ID RSP4 P decimal point(1byte) +/- (1byte) current weight(7byte) INPUT1,2,3,4(4byte) OUTPUT1,2,3,4(4byte) ETX (input or output :1 , if not : 1)																																																																																				
Ex) Current weight 7.000kg input : IN1,IN3 , output : OUT2,OUT4																																																																																					
<table style="margin: auto; border-collapse: collapse;"> <tr> <td style="padding: 0 5px;">STX</td> <td style="padding: 0 5px;">ID</td> <td style="padding: 0 5px;">R</td> <td style="padding: 0 5px;">W</td> <td style="padding: 0 5px;">R</td> <td style="padding: 0 5px;">S</td> <td style="padding: 0 5px;">P</td> <td style="padding: 0 5px;">3</td> <td style="padding: 0 5px;">+</td> <td style="padding: 0 5px;">0</td> <td style="padding: 0 5px;">0</td> <td style="padding: 0 5px;">0</td> <td style="padding: 0 5px;">7</td> </tr> <tr> <td style="border: 1px solid black; text-align: center;">02h</td> <td style="border: 1px solid black; text-align: center;">30h</td> <td style="border: 1px solid black; text-align: center;">31h</td> <td style="border: 1px solid black; text-align: center;">52h</td> <td style="border: 1px solid black; text-align: center;">57h</td> <td style="border: 1px solid black; text-align: center;">52h</td> <td style="border: 1px solid black; text-align: center;">53h</td> <td style="border: 1px solid black; text-align: center;">50h</td> <td style="border: 1px solid black; text-align: center;">33h</td> <td style="border: 1px solid black; text-align: center;">2Bh</td> <td style="border: 1px solid black; text-align: center;">30h</td> <td style="border: 1px solid black; text-align: center;">30h</td> <td style="border: 1px solid black; text-align: center;">37h</td> </tr> <tr> <td style="padding: 0 5px;">0</td> <td style="padding: 0 5px;">0</td> <td style="padding: 0 5px;">0</td> <td style="padding: 0 5px;">1</td> <td style="padding: 0 5px;">0</td> <td style="padding: 0 5px;">1</td> <td style="padding: 0 5px;">0</td> <td style="padding: 0 5px;">0</td> <td style="padding: 0 5px;">1</td> <td style="padding: 0 5px;">0</td> <td style="padding: 0 5px;">1</td> <td colspan="2" style="padding: 0 5px;">ETX</td> </tr> <tr> <td style="border: 1px solid black; text-align: center;">30h</td> <td style="border: 1px solid black; text-align: center;">30h</td> <td style="border: 1px solid black; text-align: center;">30h</td> <td style="border: 1px solid black; text-align: center;">31h</td> <td style="border: 1px solid black; text-align: center;">30h</td> <td style="border: 1px solid black; text-align: center;">31h</td> <td style="border: 1px solid black; text-align: center;">30h</td> <td style="border: 1px solid black; text-align: center;">30h</td> <td style="border: 1px solid black; text-align: center;">31h</td> <td style="border: 1px solid black; text-align: center;">30h</td> <td style="border: 1px solid black; text-align: center;">31h</td> <td style="border: 1px solid black; text-align: center;">03h</td> <td></td> </tr> </table>		STX	ID	R	W	R	S	P	3	+	0	0	0	7	02h	30h	31h	52h	57h	52h	53h	50h	33h	2Bh	30h	30h	37h	0	0	0	1	0	1	0	0	1	0	1	ETX		30h	30h	30h	31h	30h	31h	30h	30h	31h	30h	31h	03h																																	
STX	ID	R	W	R	S	P	3	+	0	0	0	7																																																																									
02h	30h	31h	52h	57h	52h	53h	50h	33h	2Bh	30h	30h	37h																																																																									
0	0	0	1	0	1	0	0	1	0	1	ETX																																																																										
30h	30h	30h	31h	30h	31h	30h	30h	31h	30h	31h	03h																																																																										

SI 580E DIN SIZE WEIGHING CONTROLER

■ Write Command

Set as Zero (same as "ZERO" key)	
ASCII : STX ID(2Byte) WZER ETX	HEX: 02 30 31 57 5A 45 52 03
SI 580E response	normal: STX ID ACK ETX error: STX ID NAK ETX
TARE	
ASCII : STX ID(2Byte) WTAR ETX	HEX: 02 30 31 57 54 41 52 03
SI 580E response	normal: STX ID ACK ETX error: STX ID NAK ETX
TARE Reset	
ASCII : STX ID(2Byte) WTRS ETX	HEX: 02 30 31 57 54 52 53 03
SI 580E response	normal: STX ID ACK ETX error: STX ID NAK ETX
Hold	
ASCII : STX ID(2Byte) WHOL ETX	HEX: 02 30 31 57 48 4F 4C 03
SI 580E response	normal: STX ID ACK ETX error: STX ID NAK ETX
Hold Reset	
ASCII : STX ID(2Byte) WHRS ETX	HEX: 02 30 31 57 48 52 53 03
SI 580E response	normal: STX ID ACK ETX error: STX ID NAK ETX
Print	
ASCII : STX ID(2Byte) WPRT ETX	HEX: 02 30 31 57 50 52 54 03
SI 580E response	normal: STX ID ACK ETX error: STX ID NAK ETX
Print Grand Total	
ASCII : STX ID(2Byte) WGPR ETX	HEX: 02 30 31 57 47 50 52 03
SI 580E response	normal: STX ID ACK ETX error: STX ID NAK ETX
Delete Grand Total	
ASCII : STX ID(2Byte) WGTC ETX	HEX: 02 30 31 57 47 54 43 03
SI 580E response	normal: STX ID ACK ETX error: STX ID NAK ETX
RUN	
ASCII : STX ID(2Byte) WSTR ETX	HEX: 02 30 31 57 53 54 52 03
SI 580E response	normal: STX ID ACK ETX error: STX ID NAK ETX
STOP	
ASCII : STX ID(2Byte) WSTP ETX	HEX: 02 30 31 57 53 54 50 03
SI 580E response	normal: STX ID ACK ETX error: STX ID NAK ETX

SI 580E DIN SIZE WEIGHING CONTROLER

DATE Setting																														
ASCII : STX ID(2Byte) WDAT current DATE (6byte) ETX																														
Ex) Date : Aug 12 th ,2009																														
<table style="margin: auto; border-collapse: collapse;"> <tr> <td style="padding: 0 10px;">STX</td> <td style="padding: 0 10px;">ID</td> <td style="padding: 0 10px;">W</td> <td style="padding: 0 10px;">D</td> <td style="padding: 0 10px;">A</td> <td style="padding: 0 10px;">T</td> <td style="padding: 0 10px;">0</td> <td style="padding: 0 10px;">9</td> <td style="padding: 0 10px;">0</td> <td style="padding: 0 10px;">8</td> <td style="padding: 0 10px;">1</td> <td style="padding: 0 10px;">2</td> <td style="padding: 0 10px;">ETX</td> </tr> <tr> <td style="border: 1px solid black; padding: 2px 5px; text-align: center;">02h</td> <td style="border: 1px solid black; padding: 2px 5px; text-align: center;">30h</td> <td style="border: 1px solid black; padding: 2px 5px; text-align: center;">31h</td> <td style="border: 1px solid black; padding: 2px 5px; text-align: center;">57h</td> <td style="border: 1px solid black; padding: 2px 5px; text-align: center;">44h</td> <td style="border: 1px solid black; padding: 2px 5px; text-align: center;">41h</td> <td style="border: 1px solid black; padding: 2px 5px; text-align: center;">54h</td> <td style="border: 1px solid black; padding: 2px 5px; text-align: center;">30h</td> <td style="border: 1px solid black; padding: 2px 5px; text-align: center;">39h</td> <td style="border: 1px solid black; padding: 2px 5px; text-align: center;">30h</td> <td style="border: 1px solid black; padding: 2px 5px; text-align: center;">38h</td> <td style="border: 1px solid black; padding: 2px 5px; text-align: center;">31h</td> <td style="border: 1px solid black; padding: 2px 5px; text-align: center;">32h</td> <td style="border: 1px solid black; padding: 2px 5px; text-align: center;">03h</td> </tr> </table>		STX	ID	W	D	A	T	0	9	0	8	1	2	ETX	02h	30h	31h	57h	44h	41h	54h	30h	39h	30h	38h	31h	32h	03h		
STX	ID	W	D	A	T	0	9	0	8	1	2	ETX																		
02h	30h	31h	57h	44h	41h	54h	30h	39h	30h	38h	31h	32h	03h																	
SI 580E response	normal: STX ID ACK ETX error: STX ID NAK ETX																													
TIME Setting																														
ASCII : STX ID(2Byte) WTIM Time (6byte)ETX																														
Ex) Time : 12:00:00																														
<table style="margin: auto; border-collapse: collapse;"> <tr> <td style="padding: 0 10px;">STX</td> <td style="padding: 0 10px;">ID</td> <td style="padding: 0 10px;">W</td> <td style="padding: 0 10px;">T</td> <td style="padding: 0 10px;">I</td> <td style="padding: 0 10px;">M</td> <td style="padding: 0 10px;">1</td> <td style="padding: 0 10px;">2</td> <td style="padding: 0 10px;">0</td> <td style="padding: 0 10px;">0</td> <td style="padding: 0 10px;">0</td> <td style="padding: 0 10px;">0</td> <td style="padding: 0 10px;">ETX</td> </tr> <tr> <td style="border: 1px solid black; padding: 2px 5px; text-align: center;">02h</td> <td style="border: 1px solid black; padding: 2px 5px; text-align: center;">30h</td> <td style="border: 1px solid black; padding: 2px 5px; text-align: center;">31h</td> <td style="border: 1px solid black; padding: 2px 5px; text-align: center;">57h</td> <td style="border: 1px solid black; padding: 2px 5px; text-align: center;">54h</td> <td style="border: 1px solid black; padding: 2px 5px; text-align: center;">49h</td> <td style="border: 1px solid black; padding: 2px 5px; text-align: center;">4Dh</td> <td style="border: 1px solid black; padding: 2px 5px; text-align: center;">31h</td> <td style="border: 1px solid black; padding: 2px 5px; text-align: center;">32h</td> <td style="border: 1px solid black; padding: 2px 5px; text-align: center;">30h</td> <td style="border: 1px solid black; padding: 2px 5px; text-align: center;">30h</td> <td style="border: 1px solid black; padding: 2px 5px; text-align: center;">30h</td> <td style="border: 1px solid black; padding: 2px 5px; text-align: center;">30h</td> <td style="border: 1px solid black; padding: 2px 5px; text-align: center;">03h</td> </tr> </table>		STX	ID	W	T	I	M	1	2	0	0	0	0	ETX	02h	30h	31h	57h	54h	49h	4Dh	31h	32h	30h	30h	30h	30h	03h		
STX	ID	W	T	I	M	1	2	0	0	0	0	ETX																		
02h	30h	31h	57h	54h	49h	4Dh	31h	32h	30h	30h	30h	30h	03h																	
SI 580E response	normal: STX ID ACK ETX error: STX ID NAK ETX																													
Change S/N																														
ASCII : STX ID(2Byte) WSNO S/N(6byte)ETX																														
Ex) S/N is changed to 100																														
<table style="margin: auto; border-collapse: collapse;"> <tr> <td style="padding: 0 10px;">STX</td> <td style="padding: 0 10px;">ID</td> <td style="padding: 0 10px;">W</td> <td style="padding: 0 10px;">S</td> <td style="padding: 0 10px;">N</td> <td style="padding: 0 10px;">O</td> <td style="padding: 0 10px;">0</td> <td style="padding: 0 10px;">0</td> <td style="padding: 0 10px;">0</td> <td style="padding: 0 10px;">0</td> <td style="padding: 0 10px;">1</td> <td style="padding: 0 10px;">0</td> <td style="padding: 0 10px;">0</td> <td style="padding: 0 10px;">ETX</td> </tr> <tr> <td style="border: 1px solid black; padding: 2px 5px; text-align: center;">02h</td> <td style="border: 1px solid black; padding: 2px 5px; text-align: center;">30h</td> <td style="border: 1px solid black; padding: 2px 5px; text-align: center;">31h</td> <td style="border: 1px solid black; padding: 2px 5px; text-align: center;">57h</td> <td style="border: 1px solid black; padding: 2px 5px; text-align: center;">53h</td> <td style="border: 1px solid black; padding: 2px 5px; text-align: center;">4Eh</td> <td style="border: 1px solid black; padding: 2px 5px; text-align: center;">4Fh</td> <td style="border: 1px solid black; padding: 2px 5px; text-align: center;">30h</td> <td style="border: 1px solid black; padding: 2px 5px; text-align: center;">30h</td> <td style="border: 1px solid black; padding: 2px 5px; text-align: center;">30h</td> <td style="border: 1px solid black; padding: 2px 5px; text-align: center;">31h</td> <td style="border: 1px solid black; padding: 2px 5px; text-align: center;">30h</td> <td style="border: 1px solid black; padding: 2px 5px; text-align: center;">30h</td> <td style="border: 1px solid black; padding: 2px 5px; text-align: center;">03h</td> </tr> </table>		STX	ID	W	S	N	O	0	0	0	0	1	0	0	ETX	02h	30h	31h	57h	53h	4Eh	4Fh	30h	30h	30h	31h	30h	30h	03h	
STX	ID	W	S	N	O	0	0	0	0	1	0	0	ETX																	
02h	30h	31h	57h	53h	4Eh	4Fh	30h	30h	30h	31h	30h	30h	03h																	
SI 580E response	normal: STX ID ACK ETX error: STX ID NAK ETX																													
Setting SP1																														
ASCII : STX ID(2Byte) WSP1 SP1set value(7byte) ETX																														
Ex) SP1 : 5.000kg (decimal point : 0.000)																														
<table style="margin: auto; border-collapse: collapse;"> <tr> <td style="padding: 0 10px;">STX</td> <td style="padding: 0 10px;">ID</td> <td style="padding: 0 10px;">W</td> <td style="padding: 0 10px;">S</td> <td style="padding: 0 10px;">P</td> <td style="padding: 0 10px;">1</td> <td style="padding: 0 10px;">0</td> <td style="padding: 0 10px;">0</td> <td style="padding: 0 10px;">0</td> <td style="padding: 0 10px;">5</td> <td style="padding: 0 10px;">0</td> <td style="padding: 0 10px;">0</td> <td style="padding: 0 10px;">0</td> <td style="padding: 0 10px;">ETX</td> </tr> <tr> <td style="border: 1px solid black; padding: 2px 5px; text-align: center;">02h</td> <td style="border: 1px solid black; padding: 2px 5px; text-align: center;">30h</td> <td style="border: 1px solid black; padding: 2px 5px; text-align: center;">31h</td> <td style="border: 1px solid black; padding: 2px 5px; text-align: center;">57h</td> <td style="border: 1px solid black; padding: 2px 5px; text-align: center;">53h</td> <td style="border: 1px solid black; padding: 2px 5px; text-align: center;">50h</td> <td style="border: 1px solid black; padding: 2px 5px; text-align: center;">31h</td> <td style="border: 1px solid black; padding: 2px 5px; text-align: center;">30h</td> <td style="border: 1px solid black; padding: 2px 5px; text-align: center;">30h</td> <td style="border: 1px solid black; padding: 2px 5px; text-align: center;">30h</td> <td style="border: 1px solid black; padding: 2px 5px; text-align: center;">35h</td> <td style="border: 1px solid black; padding: 2px 5px; text-align: center;">30h</td> <td style="border: 1px solid black; padding: 2px 5px; text-align: center;">30h</td> <td style="border: 1px solid black; padding: 2px 5px; text-align: center;">30h</td> <td style="border: 1px solid black; padding: 2px 5px; text-align: center;">03h</td> </tr> </table>		STX	ID	W	S	P	1	0	0	0	5	0	0	0	ETX	02h	30h	31h	57h	53h	50h	31h	30h	30h	30h	35h	30h	30h	30h	03h
STX	ID	W	S	P	1	0	0	0	5	0	0	0	ETX																	
02h	30h	31h	57h	53h	50h	31h	30h	30h	30h	35h	30h	30h	30h	03h																
SI 580E response	normal: STX ID ACK ETX error: STX ID NAK ETX																													

SI 580E DIN SIZE WEIGHING CONTROLER

Setting SP2																																																																											
ASCII : STX ID(2Byte) WSP2 SP2set value(7byte) ETX																																																																											
Ex) SP2 : 6.000kg (decimal point : 0.000)																																																																											
<table style="margin: auto; border-collapse: collapse;"> <tr> <td style="padding: 0 5px;">STX</td> <td style="padding: 0 5px;">ID</td> <td style="padding: 0 5px;">W</td> <td style="padding: 0 5px;">S</td> <td style="padding: 0 5px;">P</td> <td style="padding: 0 5px;">2</td> <td style="padding: 0 5px;">0</td> <td style="padding: 0 5px;">0</td> <td style="padding: 0 5px;">0</td> <td style="padding: 0 5px;">6</td> <td style="padding: 0 5px;">0</td> <td style="padding: 0 5px;">0</td> <td style="padding: 0 5px;">0</td> <td style="padding: 0 5px;">ETX</td> </tr> <tr> <td style="border: 1px solid black; text-align: center;">02h</td> <td style="border: 1px solid black; text-align: center;">30h</td> <td style="border: 1px solid black; text-align: center;">31h</td> <td style="border: 1px solid black; text-align: center;">57h</td> <td style="border: 1px solid black; text-align: center;">53h</td> <td style="border: 1px solid black; text-align: center;">50h</td> <td style="border: 1px solid black; text-align: center;">32h</td> <td style="border: 1px solid black; text-align: center;">30h</td> <td style="border: 1px solid black; text-align: center;">30h</td> <td style="border: 1px solid black; text-align: center;">30h</td> <td style="border: 1px solid black; text-align: center;">36h</td> <td style="border: 1px solid black; text-align: center;">30h</td> <td style="border: 1px solid black; text-align: center;">30h</td> <td style="border: 1px solid black; text-align: center;">30h</td> <td style="border: 1px solid black; text-align: center;">03h</td> </tr> </table>		STX	ID	W	S	P	2	0	0	0	6	0	0	0	ETX	02h	30h	31h	57h	53h	50h	32h	30h	30h	30h	36h	30h	30h	30h	03h																																													
STX	ID	W	S	P	2	0	0	0	6	0	0	0	ETX																																																														
02h	30h	31h	57h	53h	50h	32h	30h	30h	30h	36h	30h	30h	30h	03h																																																													
SI 580E response	normal: STX ID ACK ETX error: STX ID NAK ETX																																																																										
Setting SP3																																																																											
ASCII : STX ID(2Byte) WSP3 SP3set value(7byte) ETX																																																																											
Ex) SP3 : 7.000kg (decimal point : 0.000)																																																																											
<table style="margin: auto; border-collapse: collapse;"> <tr> <td style="padding: 0 5px;">STX</td> <td style="padding: 0 5px;">ID</td> <td style="padding: 0 5px;">W</td> <td style="padding: 0 5px;">S</td> <td style="padding: 0 5px;">P</td> <td style="padding: 0 5px;">3</td> <td style="padding: 0 5px;">0</td> <td style="padding: 0 5px;">0</td> <td style="padding: 0 5px;">0</td> <td style="padding: 0 5px;">7</td> <td style="padding: 0 5px;">0</td> <td style="padding: 0 5px;">0</td> <td style="padding: 0 5px;">0</td> <td style="padding: 0 5px;">ETX</td> </tr> <tr> <td style="border: 1px solid black; text-align: center;">02h</td> <td style="border: 1px solid black; text-align: center;">30h</td> <td style="border: 1px solid black; text-align: center;">31h</td> <td style="border: 1px solid black; text-align: center;">57h</td> <td style="border: 1px solid black; text-align: center;">53h</td> <td style="border: 1px solid black; text-align: center;">50h</td> <td style="border: 1px solid black; text-align: center;">33h</td> <td style="border: 1px solid black; text-align: center;">30h</td> <td style="border: 1px solid black; text-align: center;">30h</td> <td style="border: 1px solid black; text-align: center;">30h</td> <td style="border: 1px solid black; text-align: center;">37h</td> <td style="border: 1px solid black; text-align: center;">30h</td> <td style="border: 1px solid black; text-align: center;">30h</td> <td style="border: 1px solid black; text-align: center;">30h</td> <td style="border: 1px solid black; text-align: center;">03h</td> </tr> </table>		STX	ID	W	S	P	3	0	0	0	7	0	0	0	ETX	02h	30h	31h	57h	53h	50h	33h	30h	30h	30h	37h	30h	30h	30h	03h																																													
STX	ID	W	S	P	3	0	0	0	7	0	0	0	ETX																																																														
02h	30h	31h	57h	53h	50h	33h	30h	30h	30h	37h	30h	30h	30h	03h																																																													
SI 580E response	normal: STX ID ACK ETX error: STX ID NAK ETX																																																																										
Setting SP4																																																																											
ASCII : STX ID(2Byte) WSP4 SP4set value(7byte) ETX																																																																											
Ex) SP4 : 8.000kg (decimal point 0.000)																																																																											
<table style="margin: auto; border-collapse: collapse;"> <tr> <td style="padding: 0 5px;">STX</td> <td style="padding: 0 5px;">ID</td> <td style="padding: 0 5px;">W</td> <td style="padding: 0 5px;">S</td> <td style="padding: 0 5px;">P</td> <td style="padding: 0 5px;">4</td> <td style="padding: 0 5px;">0</td> <td style="padding: 0 5px;">0</td> <td style="padding: 0 5px;">0</td> <td style="padding: 0 5px;">8</td> <td style="padding: 0 5px;">0</td> <td style="padding: 0 5px;">0</td> <td style="padding: 0 5px;">0</td> <td style="padding: 0 5px;">ETX</td> </tr> <tr> <td style="border: 1px solid black; text-align: center;">02h</td> <td style="border: 1px solid black; text-align: center;">30h</td> <td style="border: 1px solid black; text-align: center;">31h</td> <td style="border: 1px solid black; text-align: center;">57h</td> <td style="border: 1px solid black; text-align: center;">53h</td> <td style="border: 1px solid black; text-align: center;">50h</td> <td style="border: 1px solid black; text-align: center;">34h</td> <td style="border: 1px solid black; text-align: center;">30h</td> <td style="border: 1px solid black; text-align: center;">30h</td> <td style="border: 1px solid black; text-align: center;">30h</td> <td style="border: 1px solid black; text-align: center;">38h</td> <td style="border: 1px solid black; text-align: center;">30h</td> <td style="border: 1px solid black; text-align: center;">30h</td> <td style="border: 1px solid black; text-align: center;">30h</td> <td style="border: 1px solid black; text-align: center;">03h</td> </tr> </table>		STX	ID	W	S	P	4	0	0	0	8	0	0	0	ETX	02h	30h	31h	57h	53h	50h	34h	30h	30h	30h	38h	30h	30h	30h	03h																																													
STX	ID	W	S	P	4	0	0	0	8	0	0	0	ETX																																																														
02h	30h	31h	57h	53h	50h	34h	30h	30h	30h	38h	30h	30h	30h	03h																																																													
SI 580E response	normal: STX ID ACK ETX error: STX ID NAK ETX																																																																										
Setting SP1, 2, 3, 4																																																																											
ASCII : STX ID(2Byte) WSPA SP1set value(7byte) SP2set value(7byte) SP3set value(7byte) SP4set value(7byte) ETX																																																																											
Ex) SP1 : 5.000kg, SP2 : 6.000kg, SP3 : 7.000kg, SP4 : 8.000kg (decimal point : 0.000)																																																																											
<table style="margin: auto; border-collapse: collapse;"> <tr> <td style="padding: 0 5px;">STX</td> <td style="padding: 0 5px;">ID</td> <td style="padding: 0 5px;">W</td> <td style="padding: 0 5px;">S</td> <td style="padding: 0 5px;">P</td> <td style="padding: 0 5px;">A</td> <td style="padding: 0 5px;">0</td> <td style="padding: 0 5px;">0</td> <td style="padding: 0 5px;">0</td> <td style="padding: 0 5px;">5</td> <td style="padding: 0 5px;">0</td> <td style="padding: 0 5px;">0</td> <td style="padding: 0 5px;">0</td> <td style="padding: 0 5px;">0</td> <td style="padding: 0 5px;">0</td> <td style="padding: 0 5px;">0</td> <td style="padding: 0 5px;">0</td> <td style="padding: 0 5px;">6</td> </tr> <tr> <td style="border: 1px solid black; text-align: center;">02h</td> <td style="border: 1px solid black; text-align: center;">30h</td> <td style="border: 1px solid black; text-align: center;">31h</td> <td style="border: 1px solid black; text-align: center;">57h</td> <td style="border: 1px solid black; text-align: center;">53h</td> <td style="border: 1px solid black; text-align: center;">50h</td> <td style="border: 1px solid black; text-align: center;">41h</td> <td style="border: 1px solid black; text-align: center;">30h</td> <td style="border: 1px solid black; text-align: center;">30h</td> <td style="border: 1px solid black; text-align: center;">30h</td> <td style="border: 1px solid black; text-align: center;">35h</td> <td style="border: 1px solid black; text-align: center;">30h</td> <td style="border: 1px solid black; text-align: center;">30h</td> <td style="border: 1px solid black; text-align: center;">30h</td> <td style="border: 1px solid black; text-align: center;">30h</td> <td style="border: 1px solid black; text-align: center;">30h</td> <td style="border: 1px solid black; text-align: center;">30h</td> <td style="border: 1px solid black; text-align: center;">36h</td> </tr> <tr> <td style="padding: 0 5px;">0</td> <td style="padding: 0 5px;">0</td> <td style="padding: 0 5px;">0</td> <td style="padding: 0 5px;">0</td> <td style="padding: 0 5px;">0</td> <td style="padding: 0 5px;">0</td> <td style="padding: 0 5px;">7</td> <td style="padding: 0 5px;">0</td> <td style="padding: 0 5px;">0</td> <td style="padding: 0 5px;">0</td> <td style="padding: 0 5px;">0</td> <td style="padding: 0 5px;">0</td> <td style="padding: 0 5px;">0</td> <td style="padding: 0 5px;">0</td> <td style="padding: 0 5px;">8</td> <td style="padding: 0 5px;">0</td> <td style="padding: 0 5px;">0</td> <td style="padding: 0 5px;">0</td> <td style="padding: 0 5px;">ETX</td> </tr> <tr> <td style="border: 1px solid black; text-align: center;">30h</td> <td style="border: 1px solid black; text-align: center;">30h</td> <td style="border: 1px solid black; text-align: center;">30h</td> <td style="border: 1px solid black; text-align: center;">30h</td> <td style="border: 1px solid black; text-align: center;">30h</td> <td style="border: 1px solid black; text-align: center;">30h</td> <td style="border: 1px solid black; text-align: center;">37h</td> <td style="border: 1px solid black; text-align: center;">30h</td> <td style="border: 1px solid black; text-align: center;">30h</td> <td style="border: 1px solid black; text-align: center;">30h</td> <td style="border: 1px solid black; text-align: center;">30h</td> <td style="border: 1px solid black; text-align: center;">30h</td> <td style="border: 1px solid black; text-align: center;">30h</td> <td style="border: 1px solid black; text-align: center;">30h</td> <td style="border: 1px solid black; text-align: center;">38h</td> <td style="border: 1px solid black; text-align: center;">30h</td> <td style="border: 1px solid black; text-align: center;">30h</td> <td style="border: 1px solid black; text-align: center;">30h</td> <td style="border: 1px solid black; text-align: center;">03h</td> </tr> </table>		STX	ID	W	S	P	A	0	0	0	5	0	0	0	0	0	0	0	6	02h	30h	31h	57h	53h	50h	41h	30h	30h	30h	35h	30h	30h	30h	30h	30h	30h	36h	0	0	0	0	0	0	7	0	0	0	0	0	0	0	8	0	0	0	ETX	30h	30h	30h	30h	30h	30h	37h	30h	30h	30h	30h	30h	30h	30h	38h	30h	30h	30h	03h
STX	ID	W	S	P	A	0	0	0	5	0	0	0	0	0	0	0	6																																																										
02h	30h	31h	57h	53h	50h	41h	30h	30h	30h	35h	30h	30h	30h	30h	30h	30h	36h																																																										
0	0	0	0	0	0	7	0	0	0	0	0	0	0	8	0	0	0	ETX																																																									
30h	30h	30h	30h	30h	30h	37h	30h	30h	30h	30h	30h	30h	30h	38h	30h	30h	30h	03h																																																									
SI 580E response	normal: STX ID ACK ETX error: STX ID NAK ETX																																																																										

Tip Recommended Comm. Interval of WRITE COMMAND is Min. 100ms.
 Comm. Interval of WPRT is Min.300ms
 You have to guarantee Min. 100ms interval between two different commands.
 Response for WPRT will be output through Print Port, set by F32-0 or F62-02).

SI 580E DIN SIZE WEIGHING CONTROLLER

■ Command Mode Example

● READ COMMAND

Ex.) Current Weight Command(RCWT), ID No. : 01, Current Weight : 1,000kg

1) P.C Read Command Format (STX ID NO. RCWT ETX) "Check-sum" not used.

* PC transmits to SI580E

STX	ID	R	C	W	T	ETX	
02h	30h	31h	52h	43h	57h	54h	03h

* SI580E Response to PC

STX	ID	R	C	W	T	S	N	P	3	+	0	0	0	7	0	0	0	ETX	
02h	30h	31h	52h	57h	52h	53h	53h	4Eh	50h	33h	2Bh	30h	30h	30h	37h	30h	30h	30h	03h

2) When PC requests to Indicator, Format(STX ID RCWT ETX) CHCEK SUM is used.

* PC transmits to SI580E

STX	ID	R	C	W	T	BCC	ETX		
02h	30h	31h	52h	43h	57h	54h	41h	36h	03h

* SI580E Response to PC

STX	ID	R	C	W	T	S	N	P	3	+	0	0	0	7	0	0	0	5	A	ETX	
02h	30h	31h	52h	57h	52h	53h	53h	4Eh	50h	33h	2Bh	30h	30h	30h	37h	30h	30h	30h	35h	41h	03h

SI 580E DIN SIZE WEIGHING CONTROLER

● WRITE COMMAND

Ex) SP1 Setting Command, ID No : 01, New SP1 Set value : 0.600kg

1) PC Write command format (STX ID WPR1 000.600 ETX) "CHECK SUM" not use.

* PC transmits to SI580E

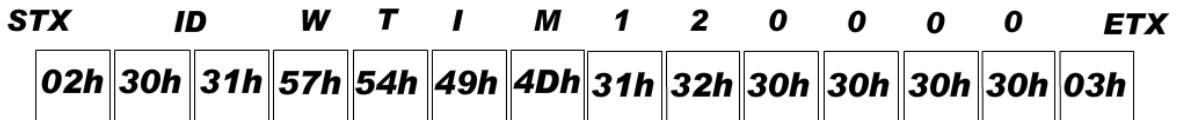

* SI580E Response to PC

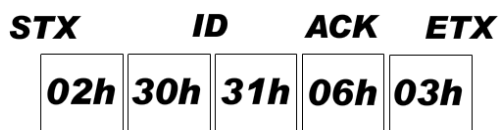

Normal operation

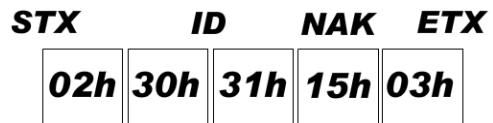

Incorrect operation

1) PC Write command format (STX ID WPR1 000.600 ETX) "CHECK SUM" use.

* PC transmits to SI580E



* SI580E Response to PC

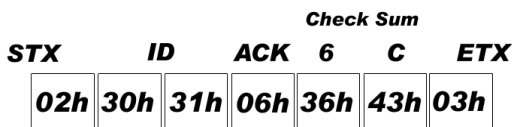

Normal operation



Incorrect operation

All Read/Write command must be use "HEX CODE".

Tip How to Calculate Check sum.

Sum the value from "STX" to "ETX" and converts to ASCII(2byte) and transfer.

Convert the Sum value(HEX) to ASCII and transmit(28byte) .

ex) The sum HEX value from STX to ETX(02,30,31,52,43,57,54,03) is 1A6h.

Then, divide 1A6h by 100h(1A6h/100h). t

he rest of result is A6h.

Calculated remainder value is A6h, then convert A6h to ASCII, 41(A), 36(6), and transfer.

SI 580E DIN SIZE WEIGHING CONTROLLER

6-2. Relay Output

4pcs Control Relay output is installed in Output Terminal.

You can make setting for these relay output through F21 function.. (A/B Dry Contact).

6-2-1. Relay Specification

Coiling Rating	12VDC
Contact Ratings	1A 24VDC

6-2-2. Relay Output Diagram.

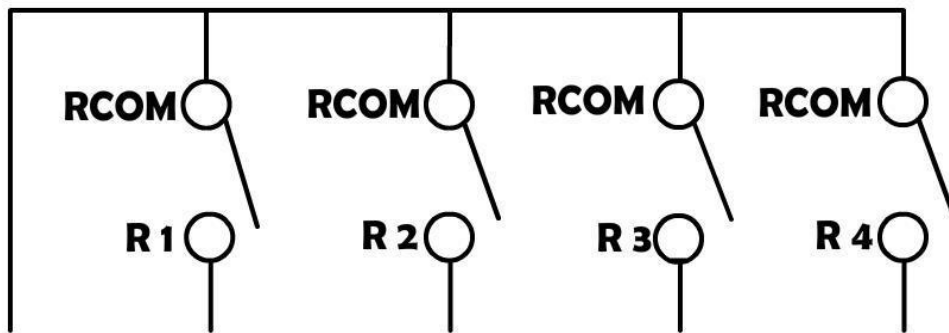

Tip Under TEST Mode ,Calibration mode and SET-POINT setting mode, the relay output will be OFF.



Caution Please check the optimal voltage of output terminal, if the high voltage power will be connected with output terminal, it may cause damage or relay or main board of indicator.

SI 580E DIN SIZE WEIGHING CONTROLER

6-3. Analogue I-Output Interface. (4~20mA)

This output card converts weight value to Analog output signal (4~20mA) and transfers to external devices(Recorder, P.L.C), controlled by voltage output.

6-3-1. Specification

Output Current	Output Range :2~22mA (Default : 4~20mA)
Accuracy	More than 1/5,000
Temperature Coefficient	0.01%°C
. Max. Loaded Impedance	500Ω MAX.

Tip

Under Calibration mode or "CELL-ERR" condition, Analogue output will not activated.
If the output is deactivated, the last output signal value will be hold until next activation.

6-3-2. Output Adjustment

- ① Default analog output value is 4mA(weight zero) , 20mA(Full using capa).
- ② The analogue output value is adjusted with DIGITAL MULTI-METER.

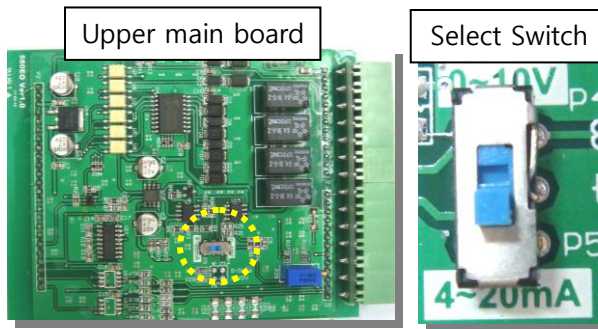

Check the setting to use the analog output switch in the upper main board.
(Default : 4~20mA)

③ How to adjust analog output value.

Step1) Connect Digital multi meter to the Indicator (A out terminal).

Step2) Enter "F81 Minimum Analog Output Setting" mode.

Step3) Adjust the displaying value of indicator with keys(by 9,999) to make Digital multi meter's value as minimum(ex:4mA) and save.(When the SI580E indicate about 5,200 , the Digital multi meter indicates about 4mA)

Step4) Enter "F82 Maximum Analog Output Setting" mode

Step5) after connect digital multi meter to the indicator, then adjust the displaying value of indicator with keys (by 32,768) to make Digital multi meter's value as maximum (ex:20mA).

※ This D/A Converter has Max. 1/5,000 accuracy, so this output is not suitable for high accuracy application, more than 1/5,000.

SI 580E DIN SIZE WEIGHING CONTROLER

6-4. Analog V-Output Interface (0~10V)

This output card converts weight value to Analog output signal (0~10V) and transfers to external devices(Recorder, P.L.C), controlled by voltage output.

6-4-1. Specification

Output Voltage	0~10V DC output
Accuracy	More than 1/1,000

Tip

According to display weight of indicator, analogue signal will be output.

The operator can determine 10V output spot by setting F51 function.

Under Calibration mode or "CELL-ERR" condition, Analogue output will not activated.

If the output is deactivated, the last output signal value will be hold until next activation

6-4-2. Output Adjustment

① Default analog output value is 0V(weight zero) , 10V(Full using capa).

② The analogue output value is adjusted with DIGITAL MULTI-METER.

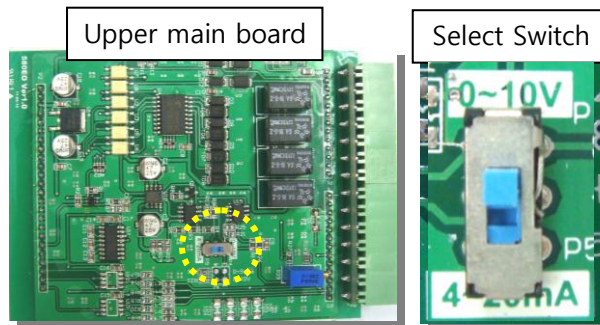

Check the setting to use the analog output switch in the upper main board.

(Default : 4~20mA)

③ How to adjust analog output value.

Step1) Connect Digital multi meter to the Indicator (A out terminal).

Step2) Enter "F81 Minimum Analog Output Setting" mode.

Step3) Adjust the displaying value of indicator with keys(by 9,999) to make Digital multi meter's value as minimum(ex:0V) and save.(When the SI580E indicates about 30,150 , the Digital multi meter indicates about 10V)

Step4) Enter "F82 Maximum Analog Output Setting" mode

Step5) after connect digital multi meter to the indicator, then adjust the displaying value of indicator with keys (by 32,768) to make Digital multi meter's value as maximum (ex:10V).

※ This D/A Converter has Max. 1/5,000 accuracy, so this output is not suitable for high accuracy application, more than 1/5,000.

SI 580E DIN SIZE WEIGHING CONTROLER

6-5 Serial Print (F32/F62-02 setting) – RS-232 Serial Interface.

It can be connected with all kinds of Serial interface printer, but the printing format is already programmed and fixed with SE7200/7300 model.

6-5-1. Printing Format

Using the RS-485 or 422 interface, please use convertor and converts to RS-232 and connect with Serial printer.

If you use RS-232 serial interface, connect directly without any convertor.

6-5-2. English Format (F47-01)

```
=====
DATE :      2009-05-10
TIME :      18:00:10
COUNT      WEIGHT
  1          + 1.330kg
  2          + 5.350kg
  3          + 1.380kg
  4          + 2.330kg
```

Continuous Print Format(F42-00)

```
=====
DATE :      2009-05-10
TIME :      18:00:10
COUNT      WEIGHT
  2          + 5.350kg

=====
DATE :      2009-05-10
TIME :      18:00:10
COUNT      WEIGHT
  3          + 1.280kg
```

Single Print Format(F42-01)

```
=====
TOTAL
DATE :      2009-05-10
TIME :      18:00:10
COUNT :      10
TOTAL WEIGHT : 258.145kg
=====
TOTAL DELETE
=====
```

Grand Total Print

(Grand Total Print delete setting, F44-01)

7. Error & Treatment

7-1. Load Cell Installation

Error	Cause	Treatment	Remarks
Weight Value is unstable	<ol style="list-style-type: none"> 1. Load cell broken 2. Load cell isolation resistance error 3. Weighing part touches other devices or some weight is on the weighing part 4. Summing Board Error 	<ol style="list-style-type: none"> 1. Measure input/output resistance of Load cell. 2. Measure Load cell isolation resistance 	<ol style="list-style-type: none"> 1. Input Resistance of "EX+" and "EX-" is about 350Ω~450Ω. 2. Output Resistance of "EX-" and "EX+" is about 350Ω. 3. Isolate Resistance is more than 100Ω
Weight Value is increased regular rate, but not return to "Zero"	<ol style="list-style-type: none"> 1. Load cell Error 2. Load cell connection Error 	<ol style="list-style-type: none"> 1. Check Load cell connection 2. Measure Load cell Resistance 	
Weight Value is increased to under Zero	Load cell Output wire (SIG+, SIG-) is switched	Make wire correction	
"UN PASS" display	Load cell broken or Indicator connection Error	<ol style="list-style-type: none"> Load cell Check Load cell connection Check 	
	Power was "ON" when some weight is on the load cell?	Remove weight on the Load cell	
"OL" or "UL" display(Over Load)	<ol style="list-style-type: none"> 1. Load cell broken or Indicator connection Error 2. Loading over than Max. Capacity 	<ol style="list-style-type: none"> 1. Load cell Check 2. Load cell connection Check 3. Remove over loaded weight 	

SI 580E DIN SIZE WEIGHING CONTROLER

7-2. Calibration Process

Display	Cause	Treatment
<i>Err-01</i>	When Max.capacity/digit value is over 20,000	Re-input the Max. Capacity, less than 20.00 (Max. Capacity / Digit)
<i>Err-04</i>	Standard weight value is over than Max. Capacity	Re-input Standard weight value with Number keys, under Max. Capacity
<i>Err-05</i>	Standard weight value is less than 10% of Max. Capacity	Re-input Standard weight value with Number keys, more than 10% of Max. Capacity
<i>Err-06</i>	<ol style="list-style-type: none"> 1. Amp. Gain is too big 2. Sig+ and Sig- wire connection error 3. Test weight is not loaded 	<p>Check standard weight's weight with set value.</p> <p>If there is difference between set value and real weight, please re-input the value (set value is too small)</p>
<i>Err-07</i>	<ol style="list-style-type: none"> 1. Amp. Gain is too small 2. Sig+ and Sig- wire connection error 3. Test weight is not loaded 	<p>Check standard weight's weight with set value.</p> <p>If there is difference between set value and real weight, please re-input the value (set value is too big)</p>
<i>Err-08</i>	Under "F-function" model, set value is "N.A"	Check the correct value and re-input
<i>Err-A</i>	When there is continuous vibration on the weighing part,, indicator cannot process calibration any more.	<ul style="list-style-type: none"> - Find vibration cause and remove - Load cell check - Load cell cable and connecting condition check

SI 580E DIN SIZE WEIGHING CONTROLER

7-3. Digital Weighing Indicator

Display	Cause	Treatment
<p>"CELL - Er"</p> <p style="text-align: center;">or</p> <p>"OVER"</p>	<p>1. Load cell Error</p> <p>2. Load cell cable Error</p> <p>3. Load cell connection Error</p> <p>4. A/D Board Error</p> <p>5. If Analogue value is over 1,040,000.</p> <p>※ When weigh "-" value, If it is over set max capa, "OVER" is displayed.</p> <p>Ex) Even though set max capa is "100" and it is over "-100", "OVER" is displayed.</p>	<p>1. Under "TEST" mode 1, check analogue value. If you cannot get any analogue value or there is no change although adding load, please check load cell, load cell cable, connection conditions first.</p> <p>2. Replace another load cell, and check the indicator condition. If you have same problem, please replace new indicator and check A/D board error.</p> <p>3. Try to connect the indicator's A/D with the other indicator.</p> <p>4. Check the power and connection of terminal.</p>
"UNPASS"	<p>1. Power is ON, when some materials are on weighing part.</p> <p>※ Under "Normal Mode", if there are more than 20% loading of Max. capacity, "Un-Pass" display will be appeared and indicator will stay until removing the load.</p> <p>※ Setting Back-up mode it can memory empty value, and it becomes set value without displaying" Un-pass")</p>	<p>1. If you set "Normal Mode", please check weighing part empty or not before turn on the power. If there are some materials in/on weighing part, please remove those materials and turn on the power.</p> <p>2. Please try to set F02-01(Back-up) mode so that the indicator can remember first empty value.</p>
"SET"	When Power is on, "SET" displays. It means EEPROM has some problem.	Please contact the distributor or Head Office.
"HALT"	H/W has some problem.	
"E-Err"	The dead Battery	

※ Under **"CELL - Er"**, Zero key, Tare key, Hold key and print key will not be activated.

SI 580E DIN SIZE WEIGHING CONTROLER

WARRANTEE CETIFICATION		
<p>This product is passed "Sewhacnm's strict quality test.</p> <p>If there is defect of manufacturing or abnormal detection within warrantee period, please contact our Agent or Distributor with this Warrantee certificate.</p> <p>Then, we will repair or replace free of charge.</p>		
WARRANTEE CLAUSE		
<p>1. The Warrantee period, we can guarantee, is one(1) year from your purchasing date</p> <p>2. Warrantee Exception Clause</p> <ul style="list-style-type: none"> - Warrantee period is expired. - Any kinds of Mal-function or defection caused by Modification or Repair without Sewhacnm's permission. - Any kinds of Mal-function, Defection, or External damage, caused by operator - Any kinds of Mal-function, Defection, caused by using spare part from Non-Authorized Distributor or Agent. - Any kinds of Mal-function, Defection, caused by not following Warnings or Cautions mentioned on this manual. - Any kinds of Mal-function, Defection caused by "Force Majeur", like Fire, Flood. - Without presentation of this "Warrantee Certification". <p>3. Other</p> <ul style="list-style-type: none"> - Any kinds of "Warrantee Certification" without authorized Stamp is out of validity 		
<p>SEWHACNM Co.,Ltd.</p> <p>302, 102dong, Ssangyong 3rd, Bucheon Techno Park, Seokcheon-ro397beon-gil, Ojeong-Gu, Bucheon City, GyungGi-Do, KOREA</p> <p>Made in KOREA</p> <p>Website : http://www.sewhacnm.co.kr , Email : sales@sewhacnm.co.kr</p>	<p style="text-align: center;">Product</p> <p style="text-align: center;">Model</p> <p style="text-align: center;">Serial No.</p> <p style="text-align: center;">AUTHORIZED STAMP</p>	<p>Digital Weighing Indicator</p> <p style="text-align: center;">SI 580E</p> <div style="text-align: center;">  </div>

SI 580E DIN SIZE WEIGHING CONTROLER